



NORTALU[®]

www.nortalu.pt

SÉRIE PT





SÉRIE PT

Sistema PT permite fazer portões com vários modelos tanto na opção de abrir como de correr. Esta série apresenta perfis para uma solução tradicional permitindo o uso de perfis para soldar, como uma solução totalmente aperfeiçoada de forma aligeirar o processo de fabricação. Os portões de alumínio são uma excelente solução para o exterior, devido a estarem permanentemente expostos às diversas agressões climáticas. Permitindo uma cor uniforme com a caixilharia por receber exatamente o mesmo tratamento, mantendo a mesma cor e longevidade.

Soluções Construtivas:

- Portões Abrir e Correr

Vedantes:

- Material em EPDM ou PVC em conformidade com anorma aplicável.

Acessórios:

- Materiais em alumínio, zamac, aço inox e nylon em conformidade com a norma aplicável.



PT.231 *Prumo Vertical*

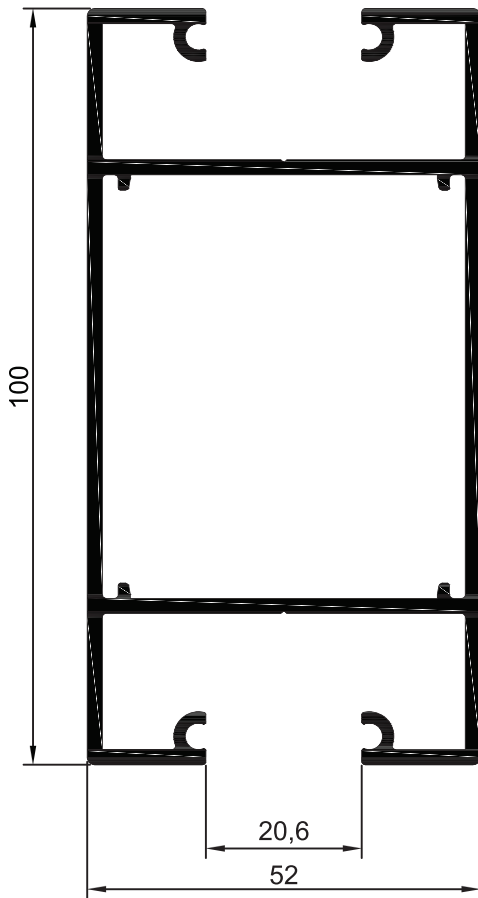

PT.233 *Travessa Central*

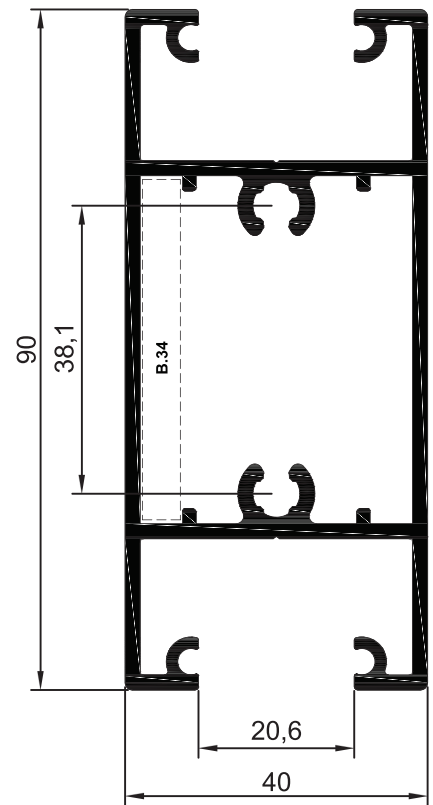

B.34 *Barra Maciça*

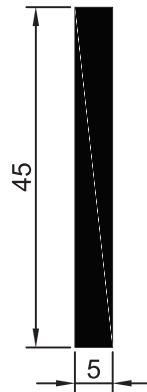

PT.253 *Bite Redutor*

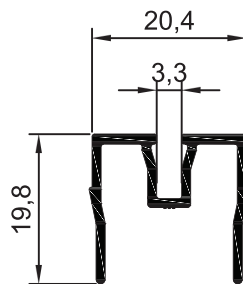

PT.241 *Prumo Vertical*

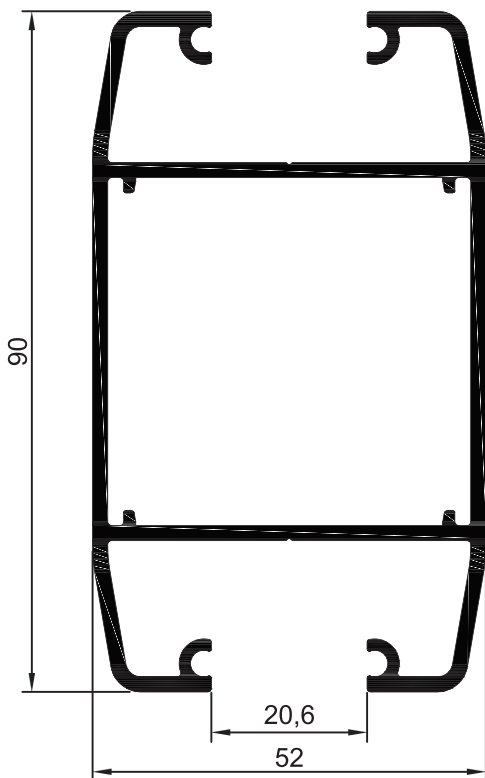

PT.242 *Travessa Central*

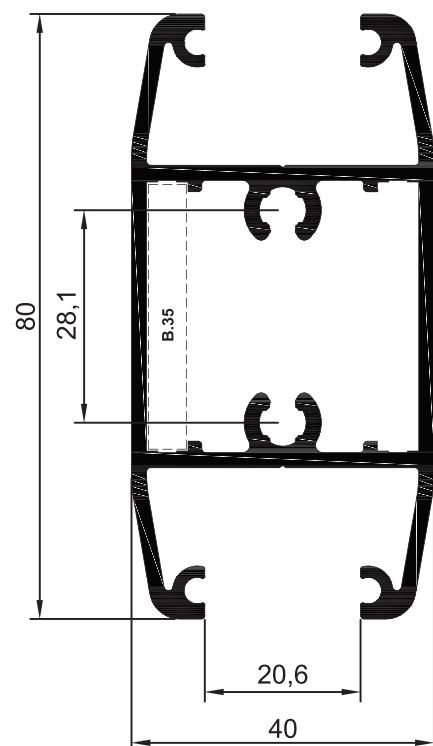

B.35 *Barra Maciça*

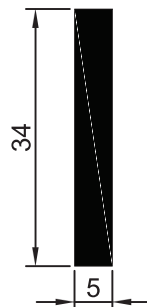

PT.234 Travessa Superior / Inferior

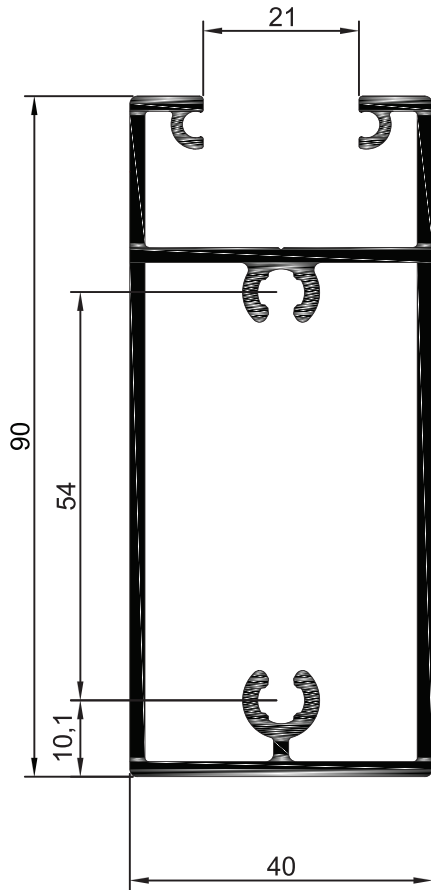

PT.236 Travessa Central

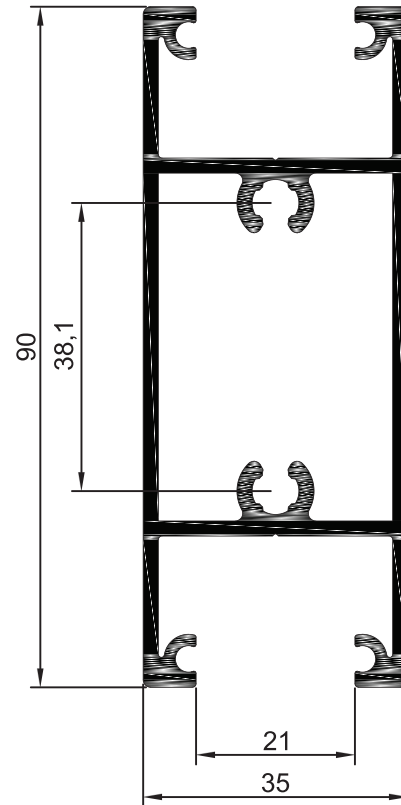

PT.235 Travessa Central

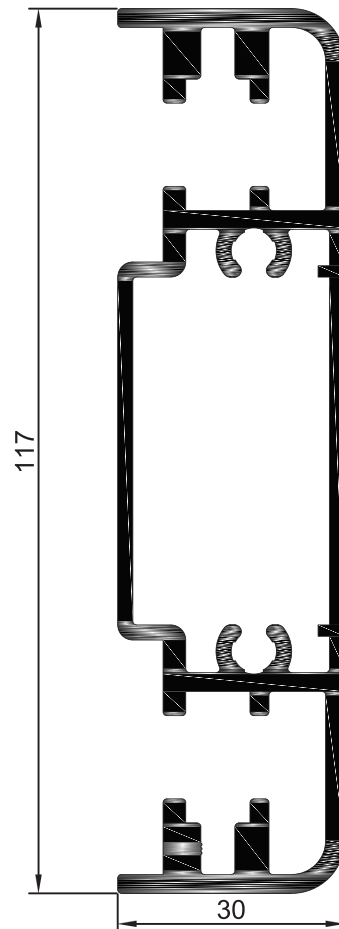
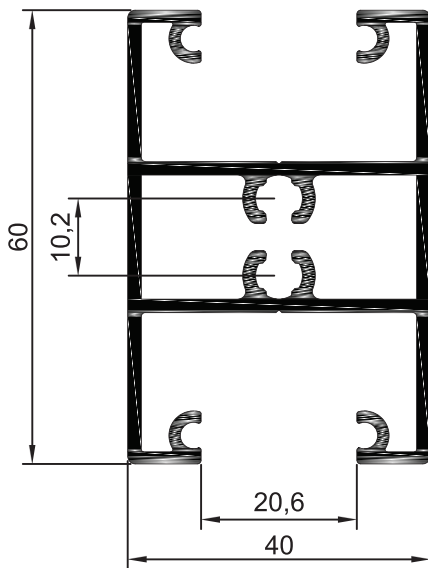

PT.226 Prumo para Guias

PT.261 Prumo Vertical (Grades)

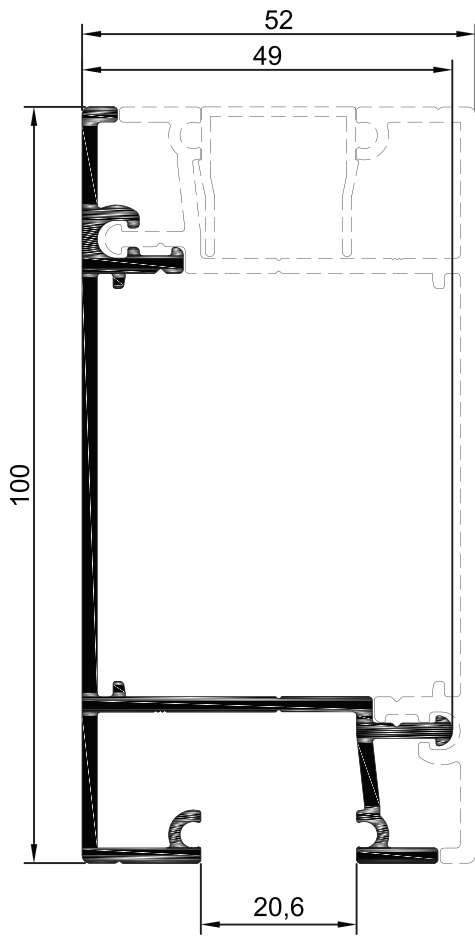

U.29 Calha "U"

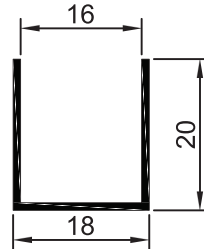

AT.30 clip



SP.24 Bite Redutor

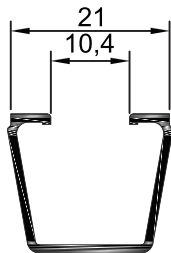

PT.251 Bite

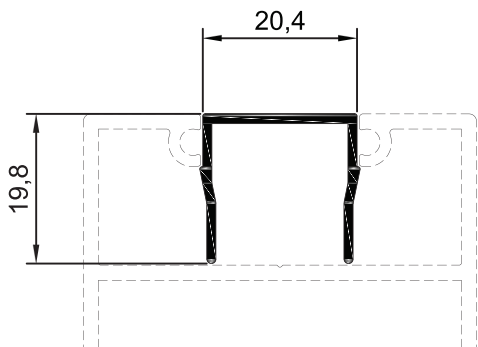

PT.230 Aro Fixo

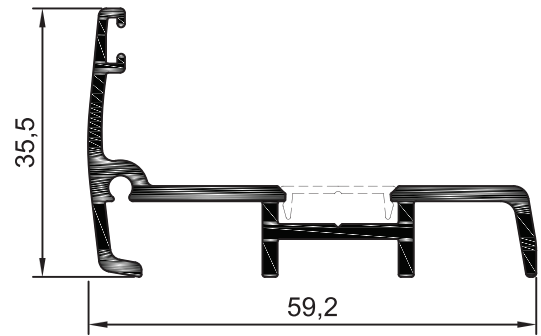

PT.237 Aro Fixo

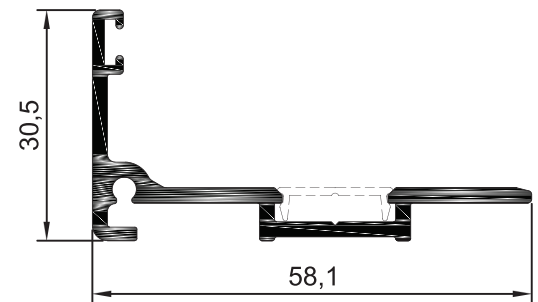

PT.238 Aro Fixo

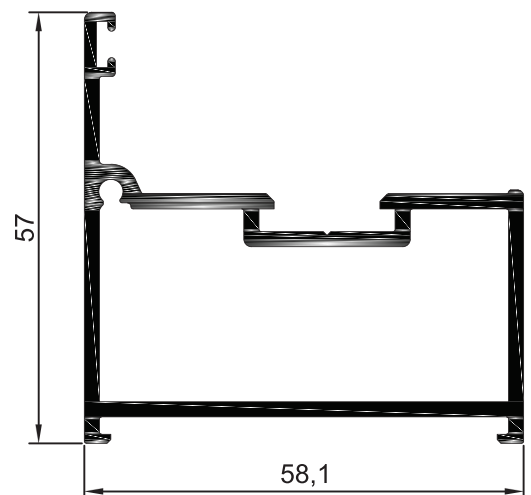

PT.214 Perfil Decorativo

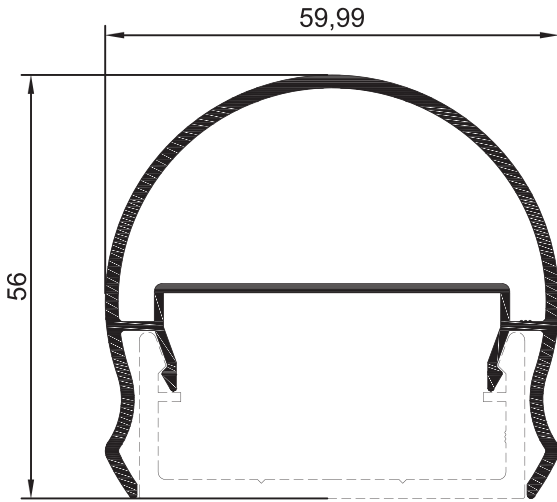

PT.213 Perfil Decorativo Capa

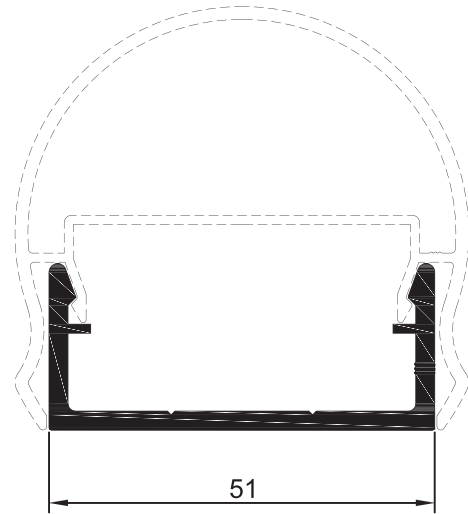

PT.229 Perfil Decorativo

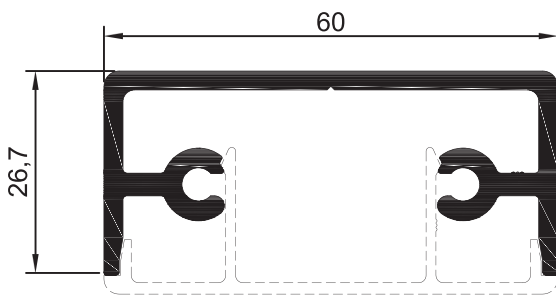

PT.218 Perfil Decorativo

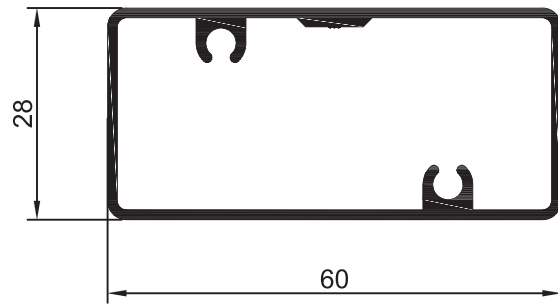

PT.208 Perfil Decorativo

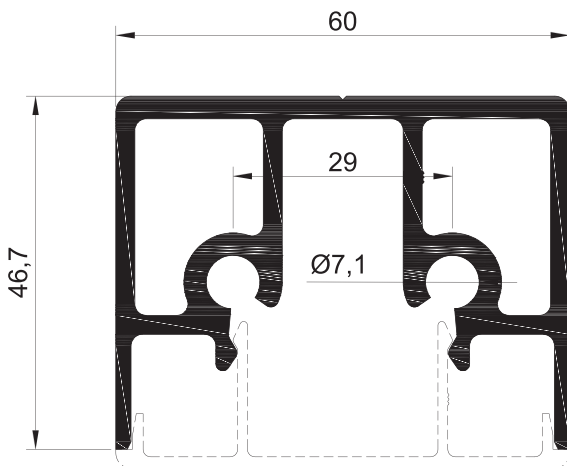

PT.209 Perfil Decorativo

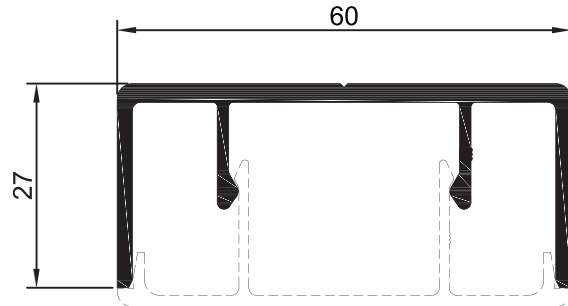

PT.210 Perfil Decorativo Capa

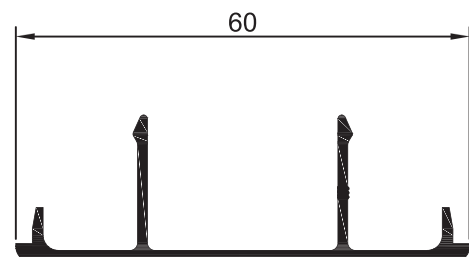

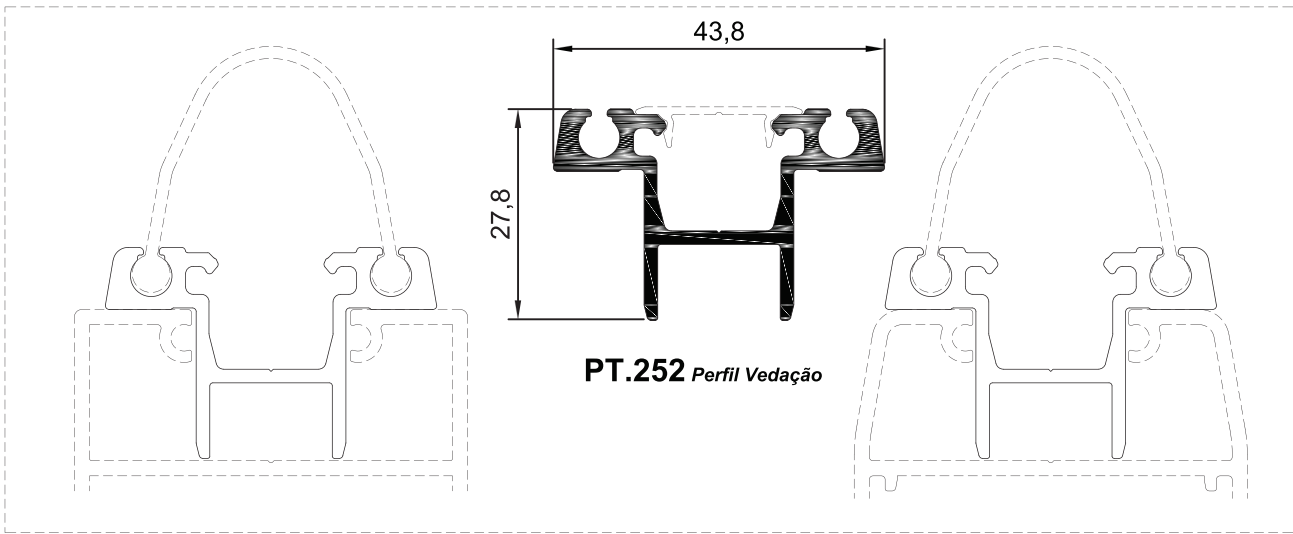

PT.225 Capa Perfil Guia

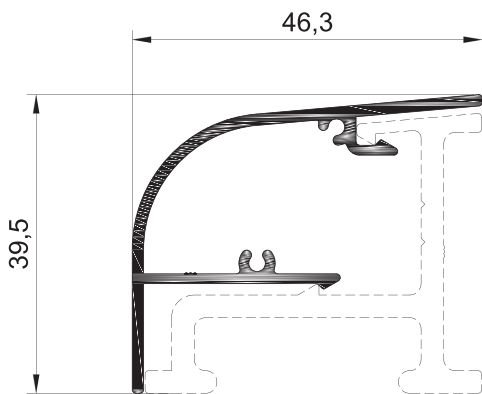

PT.224 Perfil Guia

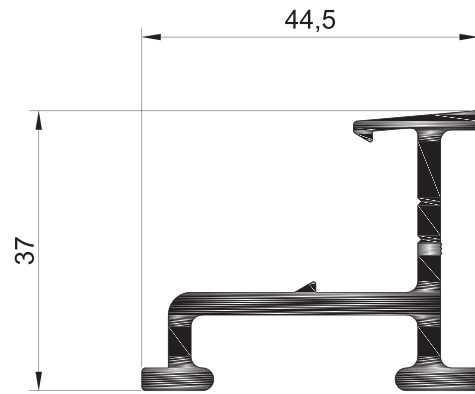

(Perfil fornecido em bruto ou acetinado)

PT.265 Capa Perfil Guia

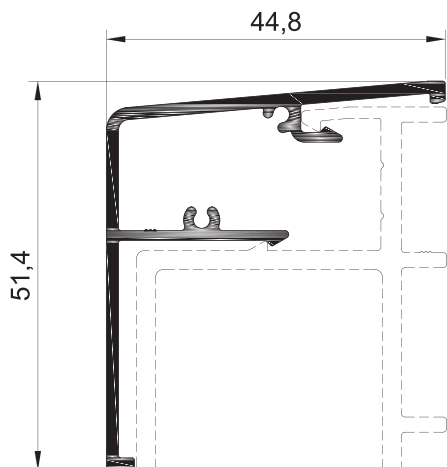

PT.264 Perfil Guia

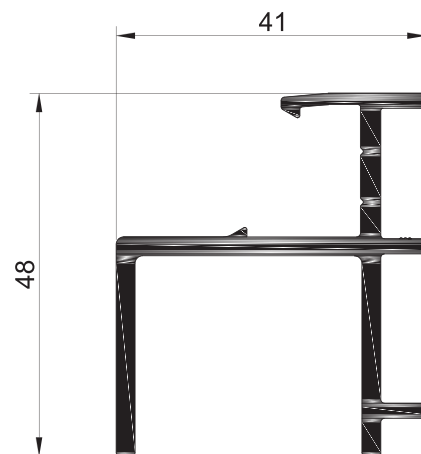

PT.02 Aro Fixo (Sistema de Abrir)

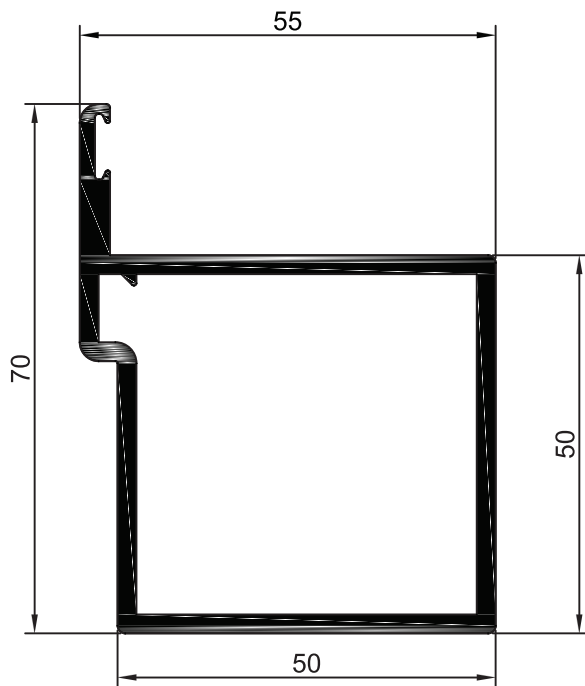

PT.01 Aro Móvel (Sistema de Abrir e Correr)

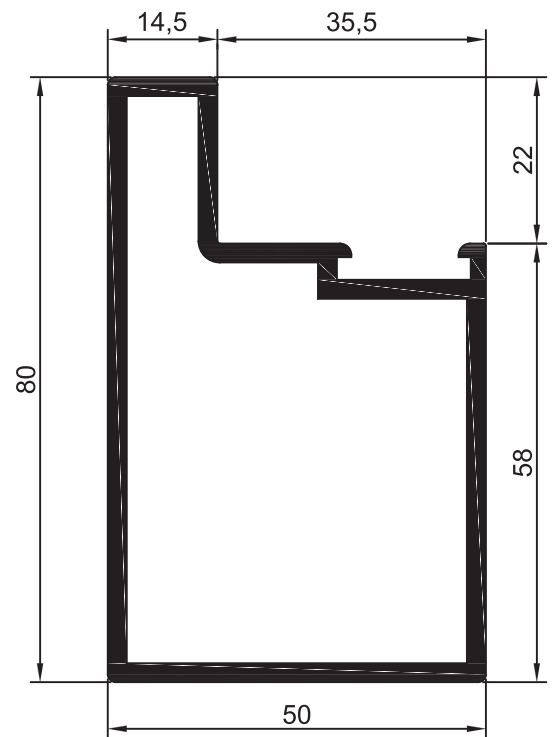

PT.03 Travessa

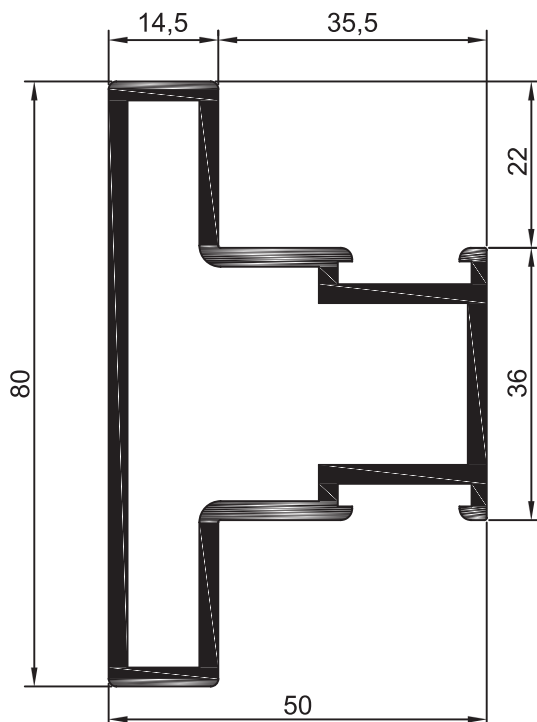

PT.04 Inversor (Sistema de Abrir)

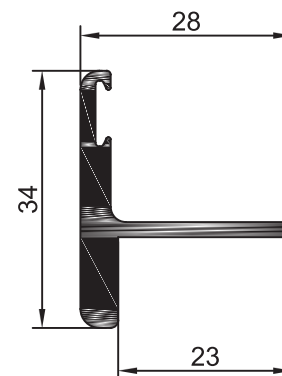

PT.104 Aro Móvel (Sistema de Abrir)

Versão PT Soldar

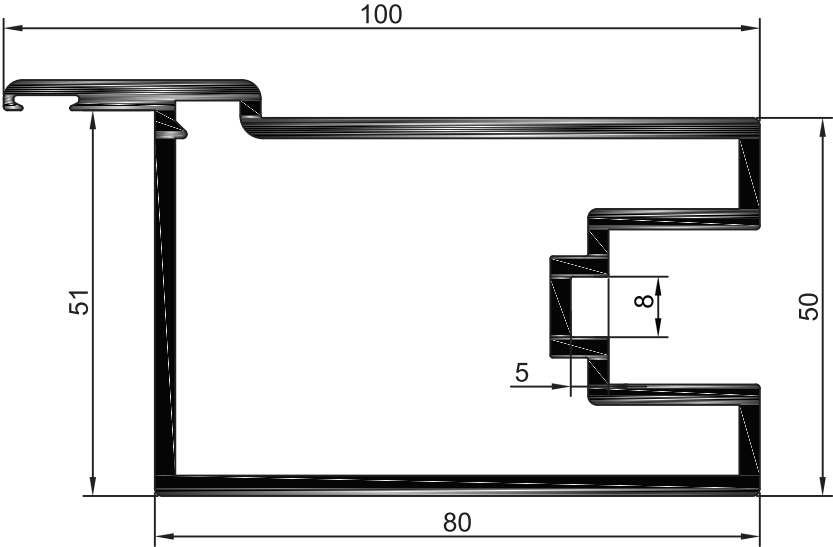

PT.103 Travessa

PT.101 Aro Móvel (Sistema de Abrir e Correr)

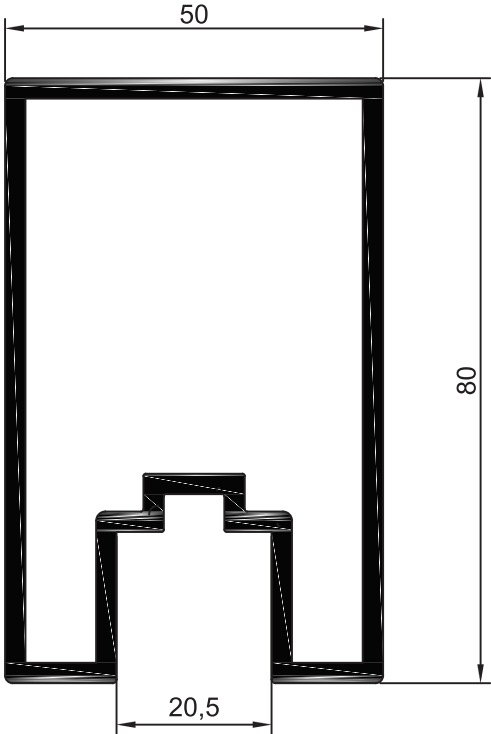
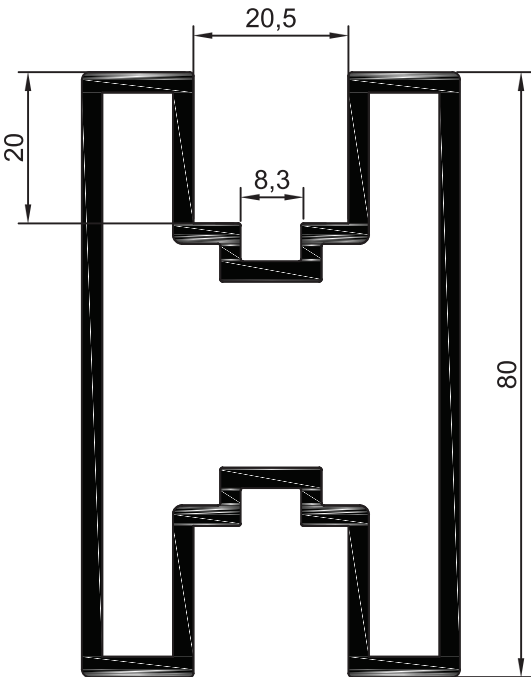

PT.15 *Perfil Poste*

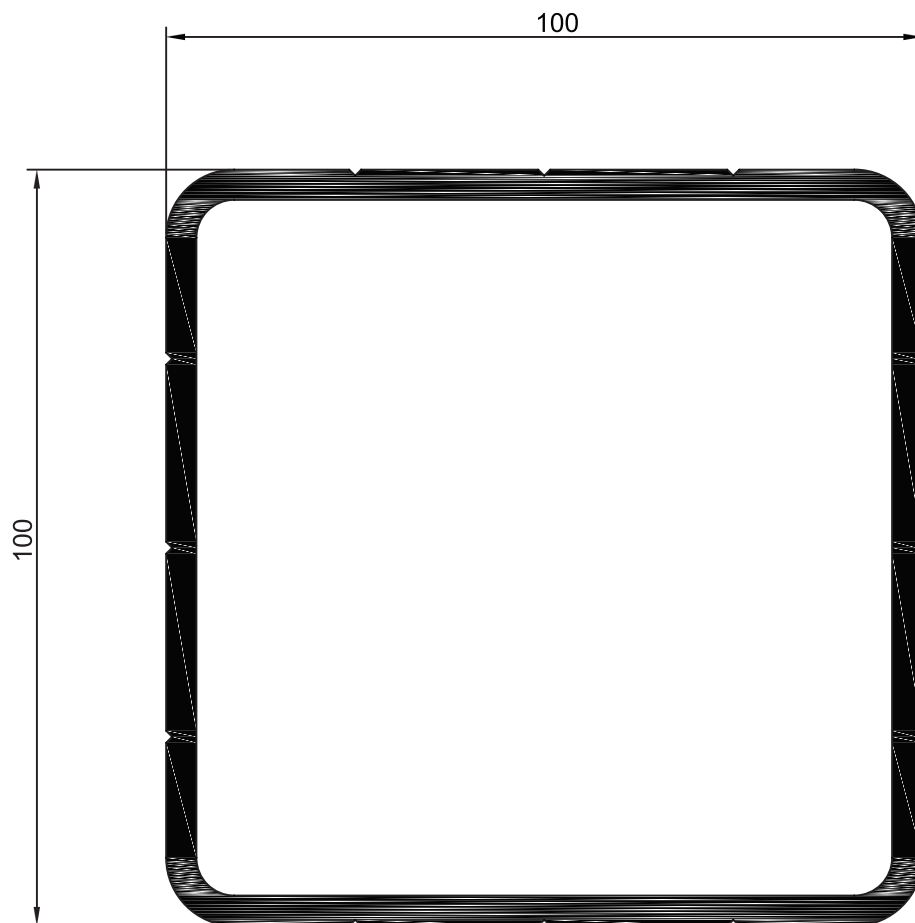

PT.15A *Tampa PT.15*

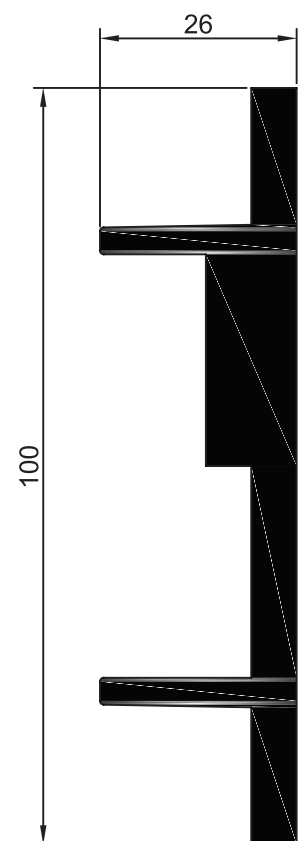

PT.203 *Perfil Poste*

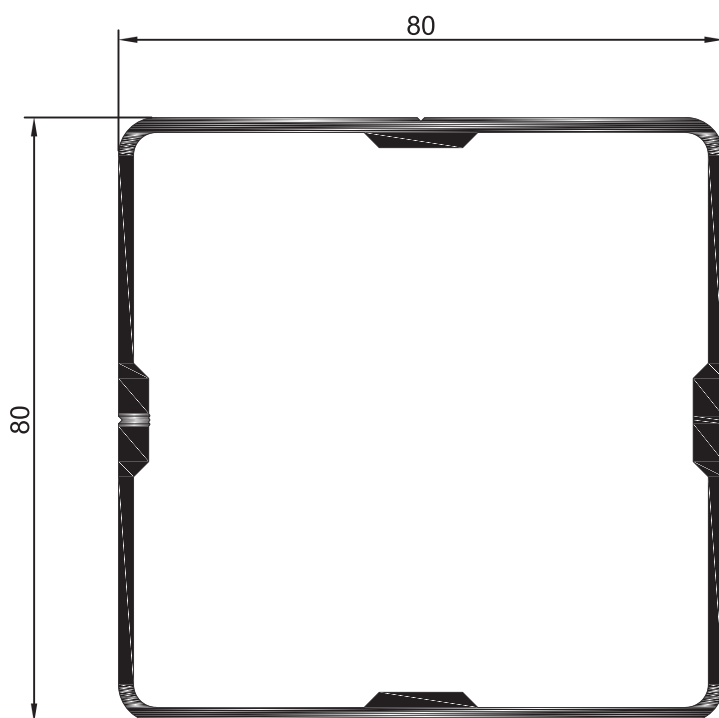

Q.21 *Perfil Poste*

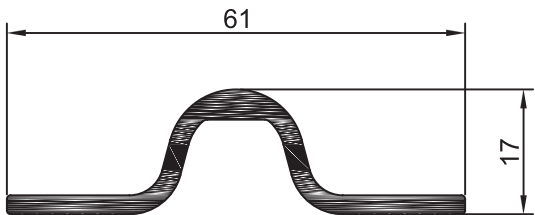
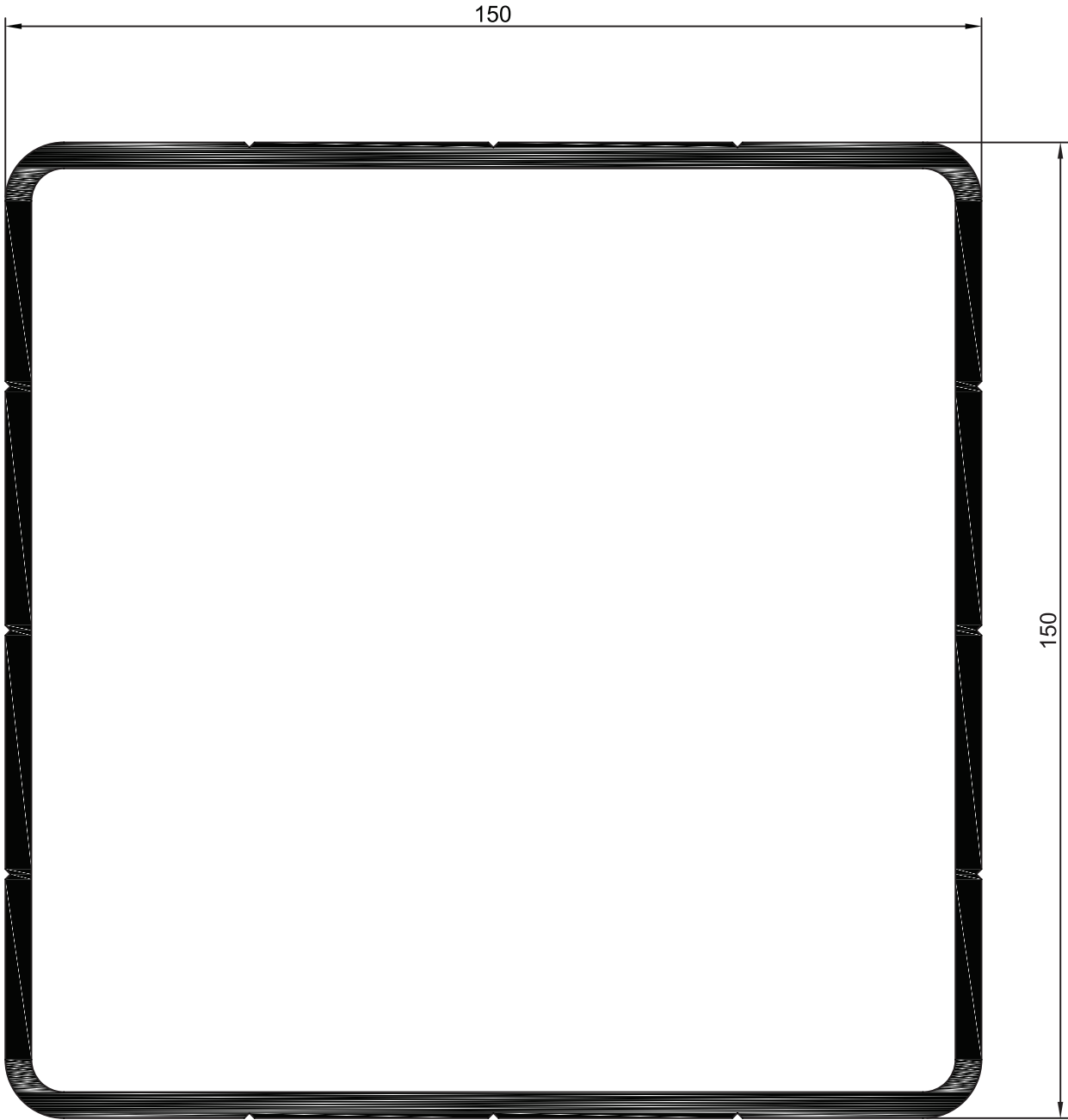

PT.123 *Rail Portão Correr*

PT.266 Aro Fixo Lateral (Sistema Correr)

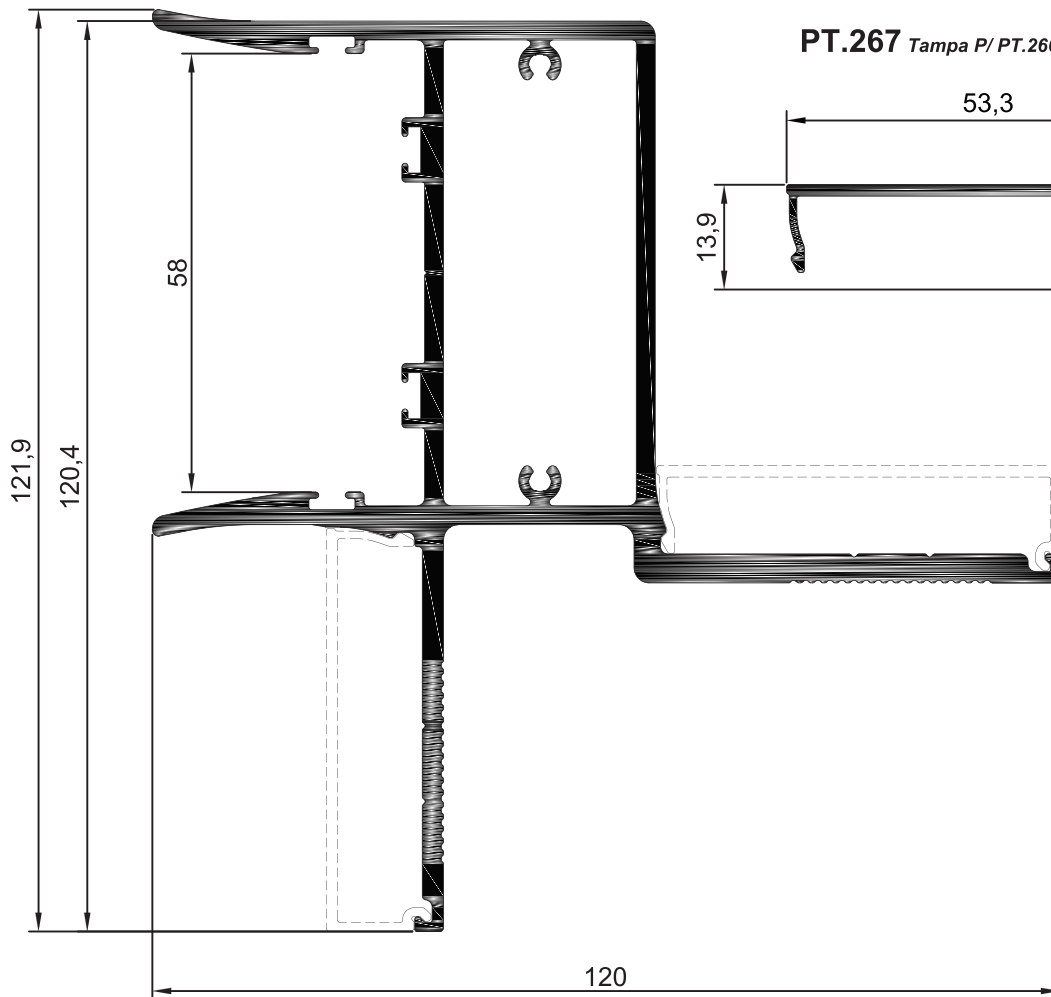

PT.267 Tampa P/PT.266

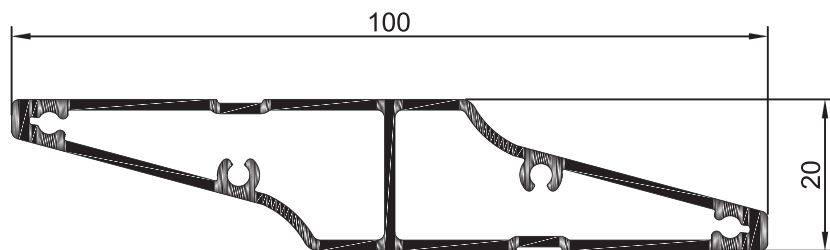

PT.250 Lâmina

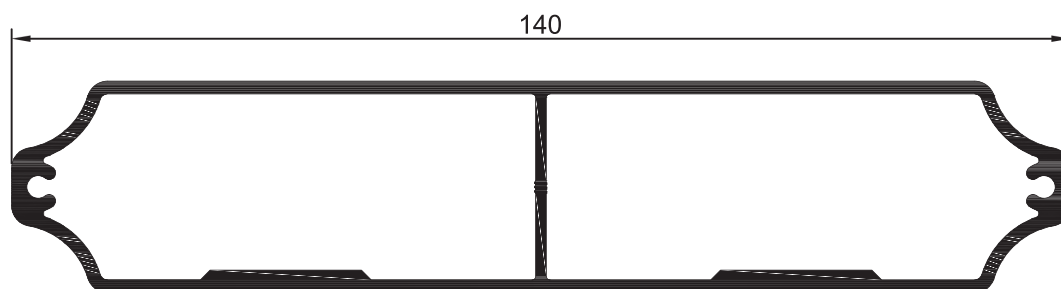

PT.217 Lâmina

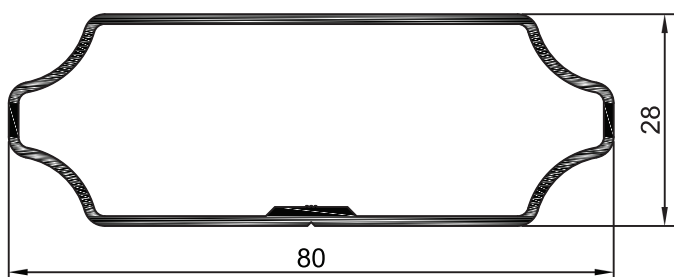
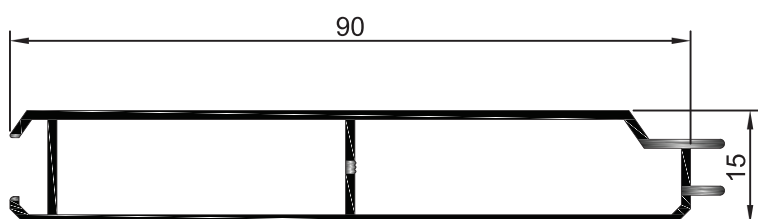
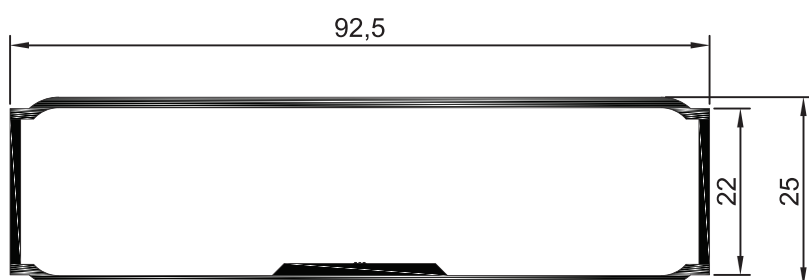
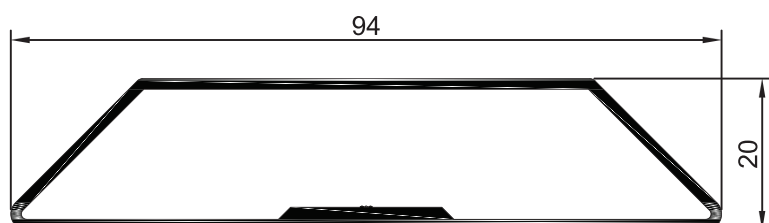
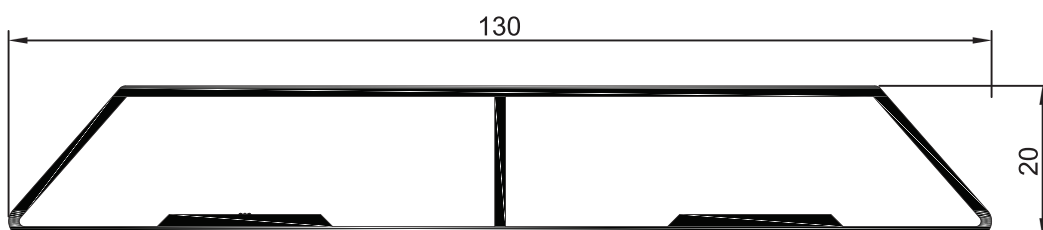
PT.202 *Lâmina*PT.216 *Lâmina*PT.205 *Lâmina*PT.206 *Lâmina*PT.212 *Lâmina*

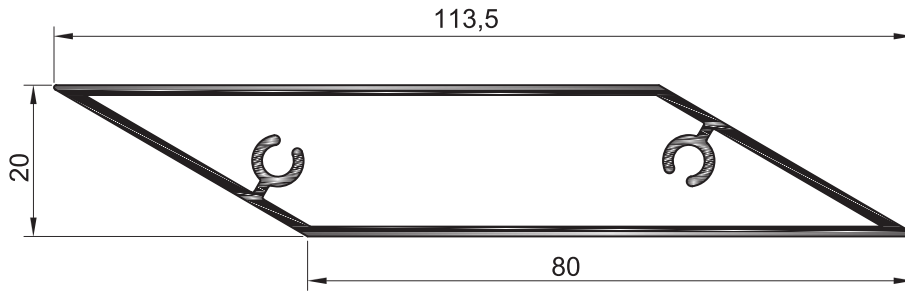

PT.270 Lâmina

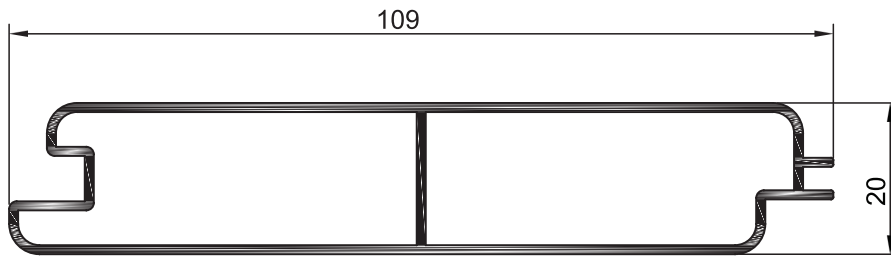

W.25 Lâmina

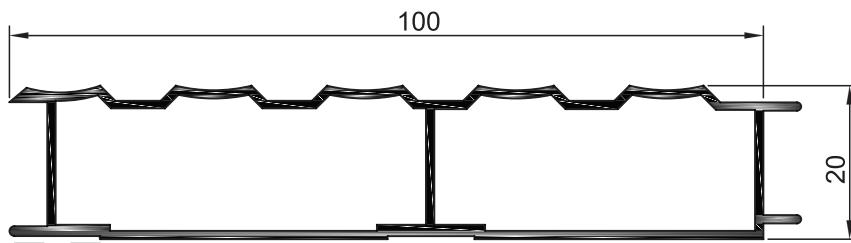

W.21 Lâmina

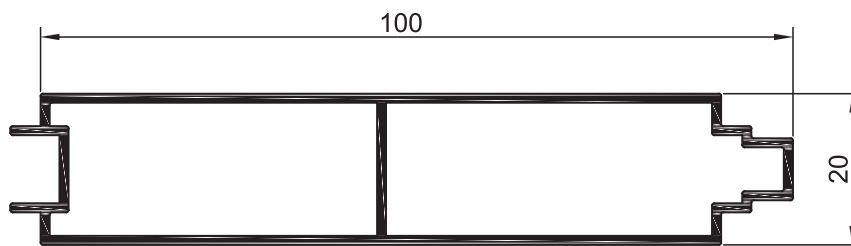

W.27 Lâmina

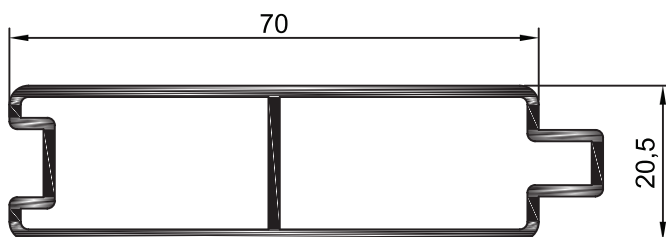

W.26 Lâmina

W.31 Lâmina

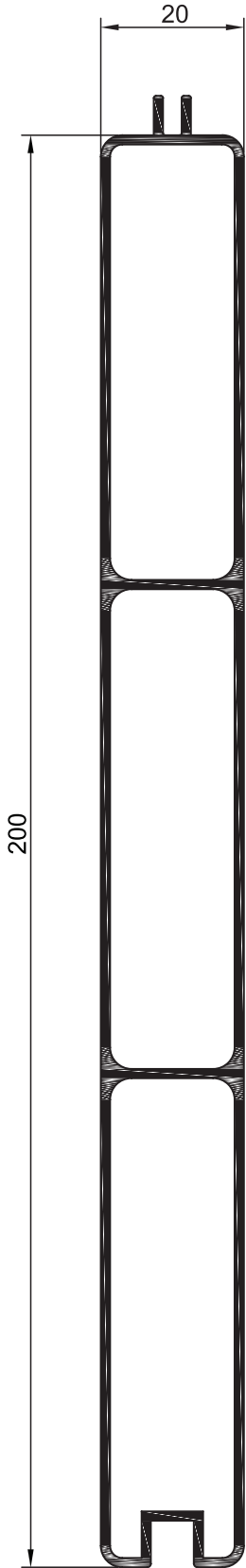

W.35 Lâmina

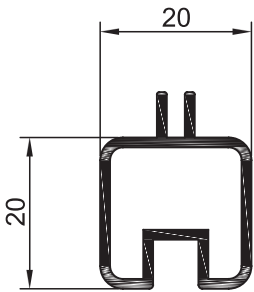

W.36 Lâmina

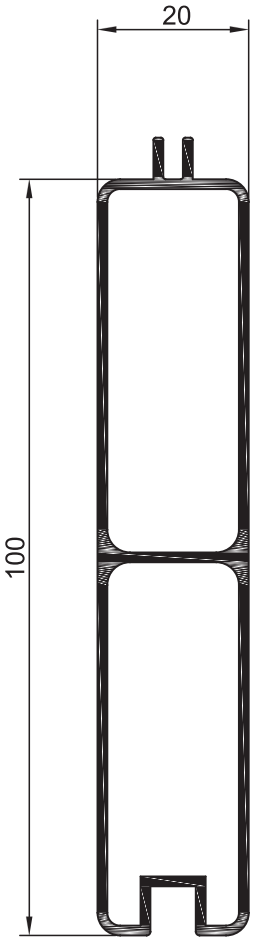

W.39 Lâmina

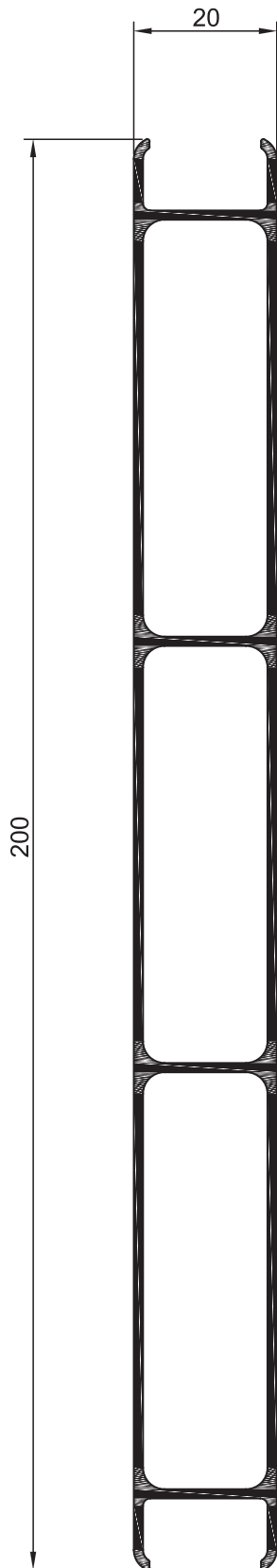

W.42 Lâmina

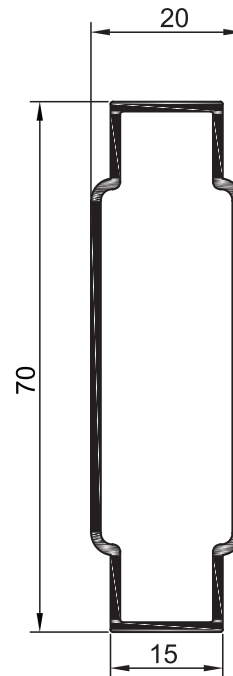

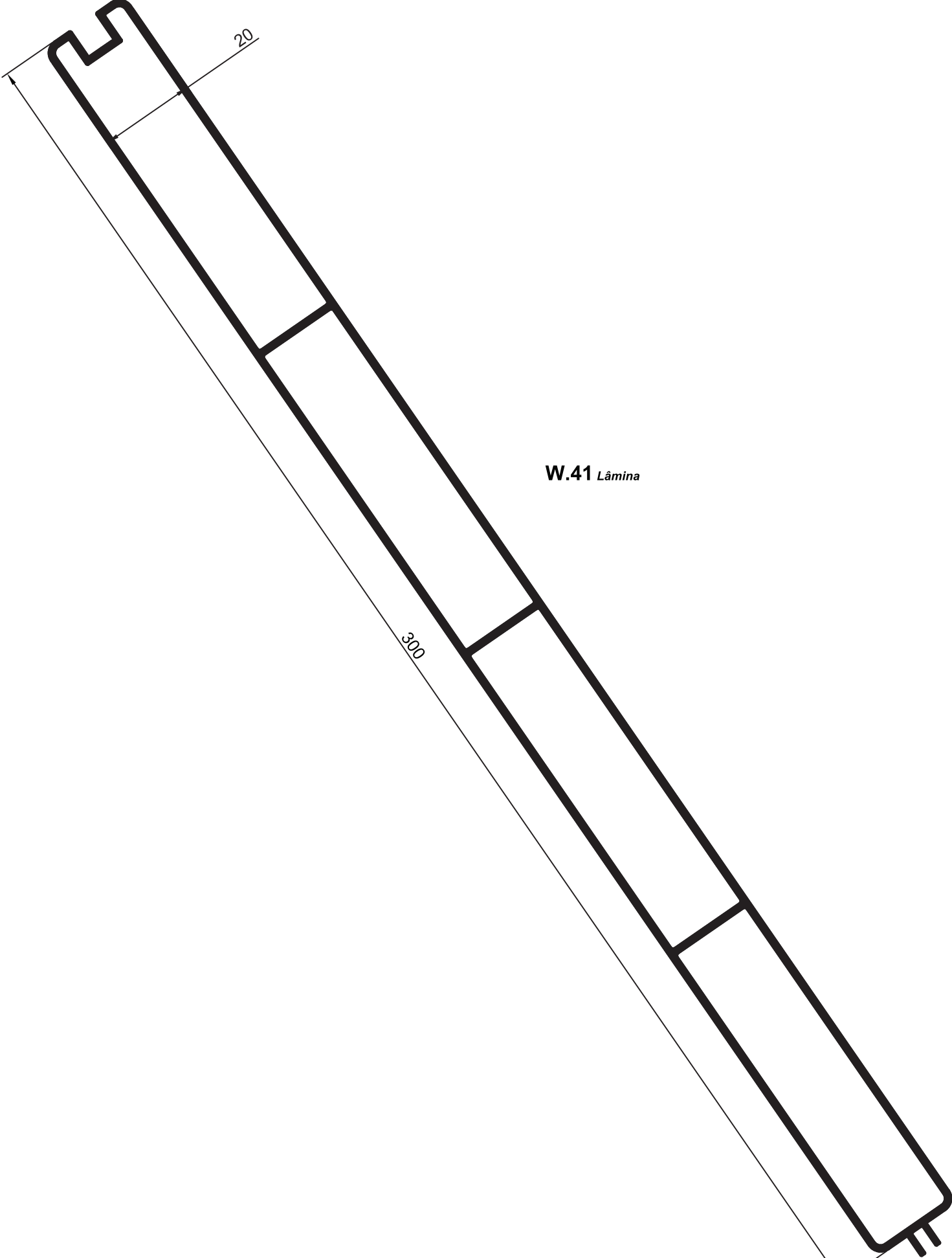

W.41 Lâmina

W.42 Lâmina

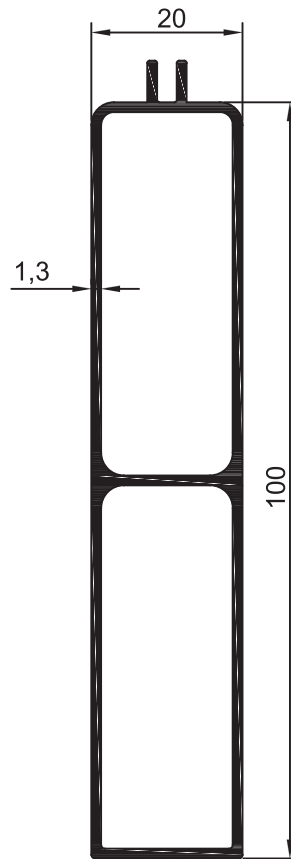
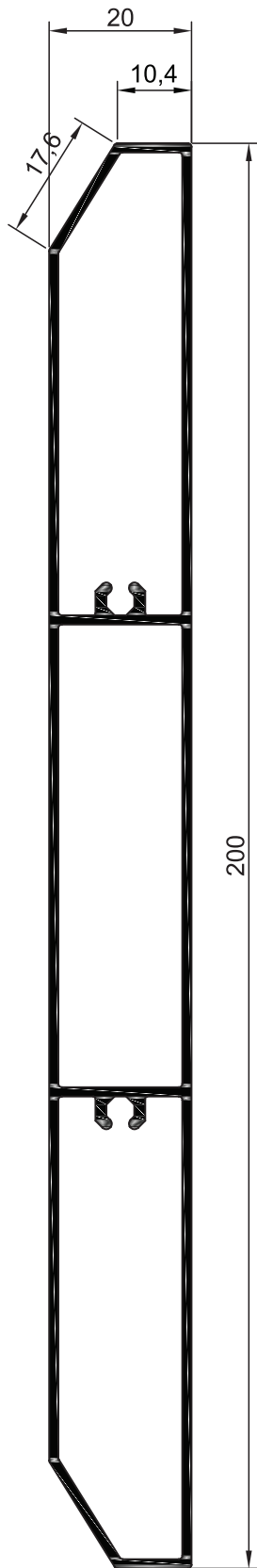

W.43 Lâmina

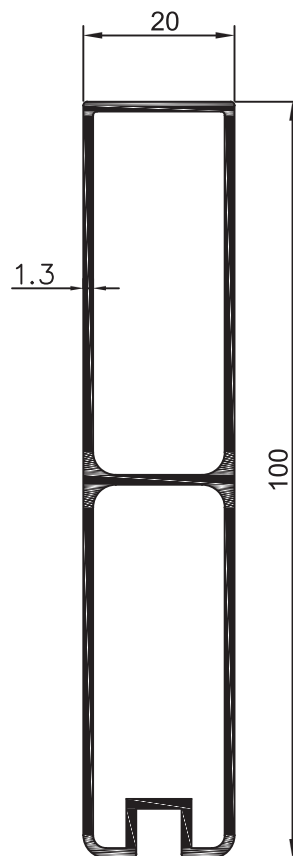

W.44 Lâmina

W.45 Lâmina

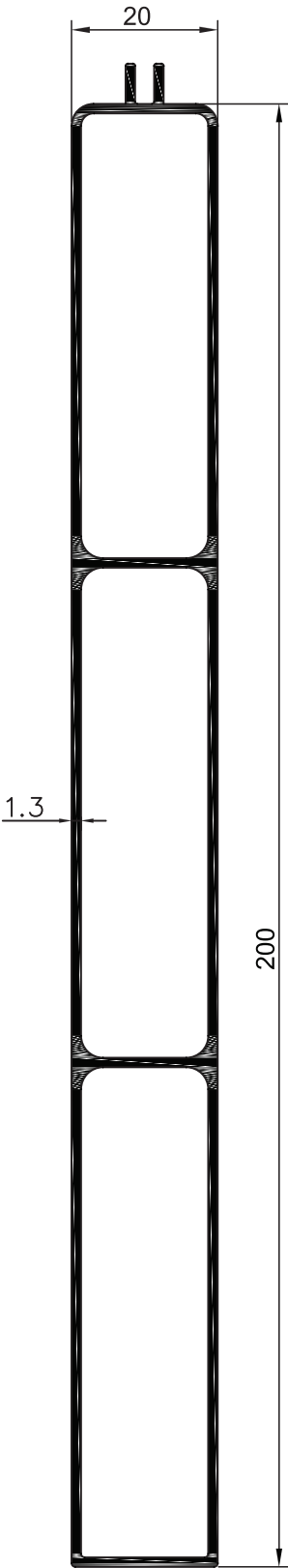

W.46 Lâmina

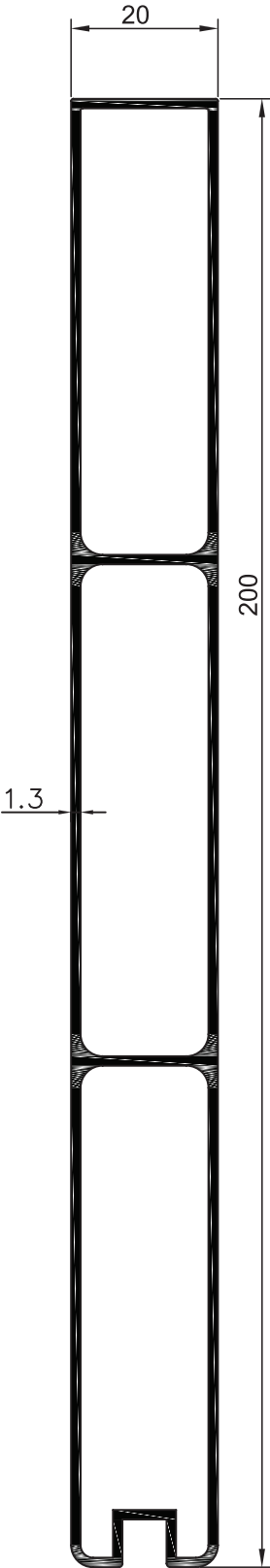



NORTALU[®]

ACESSÓRIOS

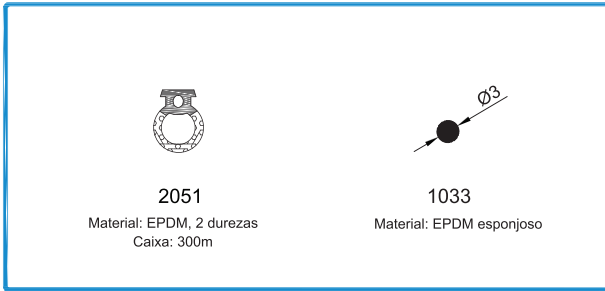

2051
Material: EPDM, 2 durezas
Caixa: 300m

1033
Material: EPDM esponjoso

208008
208221

JUNTA DE ESTANQUIDADE 2051
JUNTA VD 1033

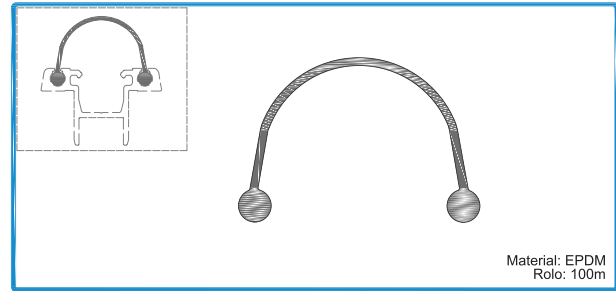

Material: EPDM
Rolo: 100m

208222

VEDANTE 2120

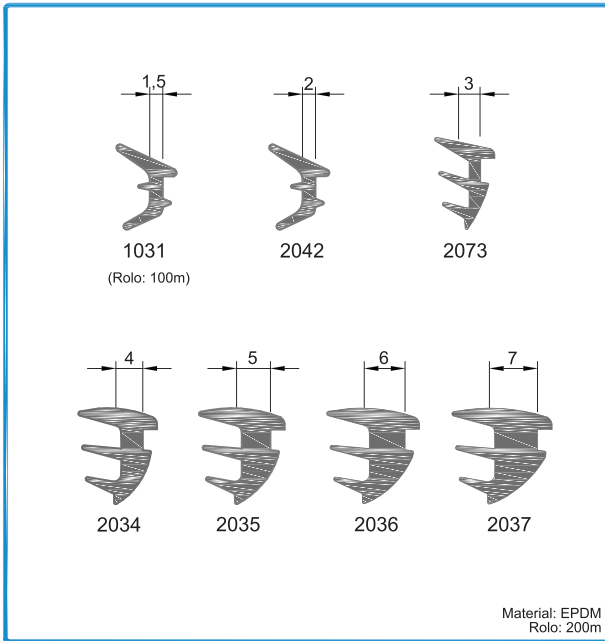

1031
(Rolo: 100m)

2042

2073

4

5

6

7

2034

2035

2036

2037

Material: EPDM
Rolo: 200m

208223 JUNTA DE CUNHA 1031
208191 JUNTA DE CUNHA 2042
208195 JUNTA DE CUNHA 2034
208196 JUNTA DE CUNHA 2035

208215 JUNTA DE CUNHA 2036
208904 JUNTA DE CUNHA 2037
208199 JUNTA DE CUNHA 2073

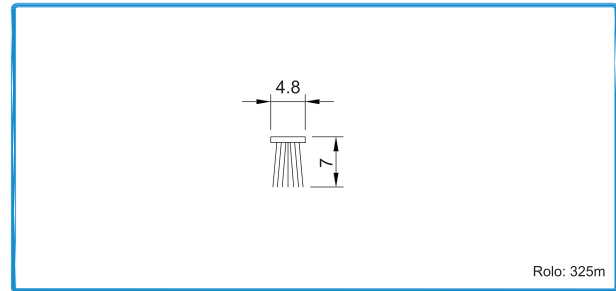

Rolo: 325m

208564

VEDANTE PELÚCIA 4.8X7

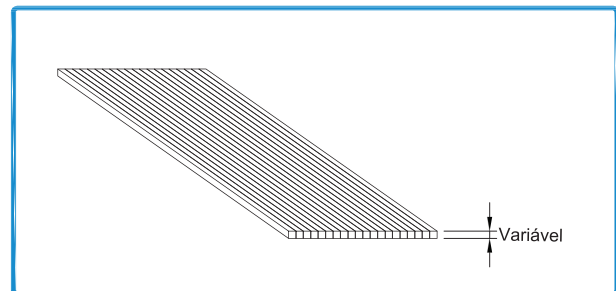

218132 CALÇO P/VIDRO 99x33x1
218113 CALÇO P/VIDRO 79x40x2
218109 CALÇO P/VIDRO 79x40x3

218111 CALÇO P/VIDRO 79x40x4
218112 CALÇO P/VIDRO 79x49x5

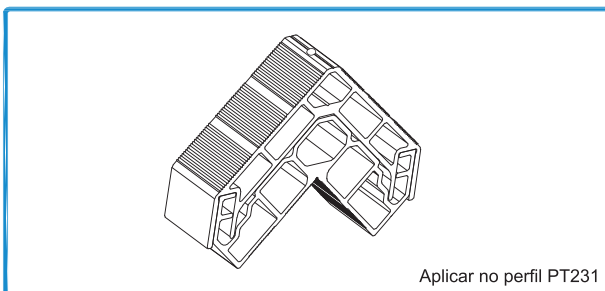

Aplicar no perfil PT231

204162

ESQUADRO ESPECIAL PA

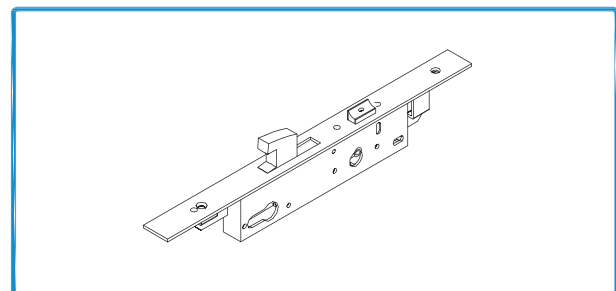

201050

FECHADURA PRUMO 7716x35

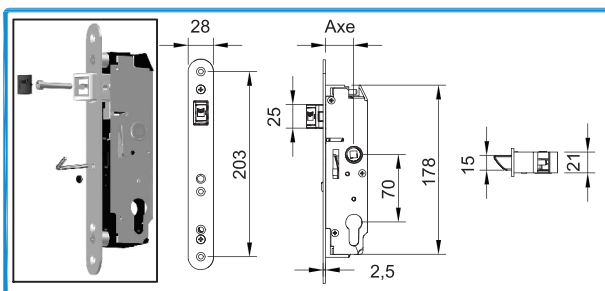

201134

FECHADURA PRUMO PA T40

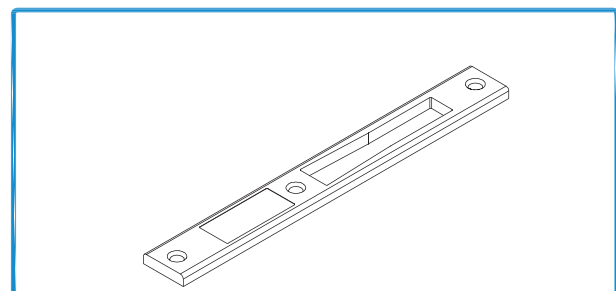

280220

TESTA FECHADURA PRUMO 2000

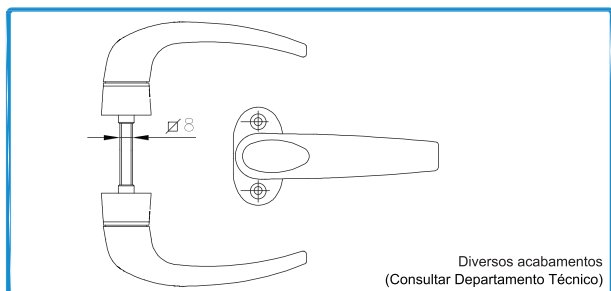

200747

PUXADOR DUPLO 874

Diversos acabamentos
(Consultar Departamento Técnico)

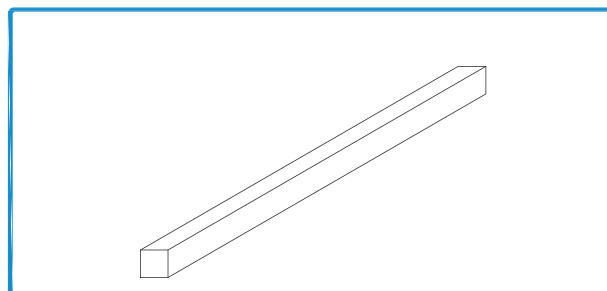

227301

QUADRA AÇO 8 x 140 mm

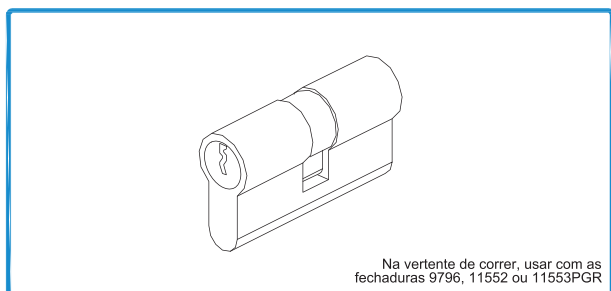

230006

SEGREDO 30/30 COM 3 CHAVES

Na vertente de correr, usar com as fechaduras 9796, 11552 ou 11553PGR

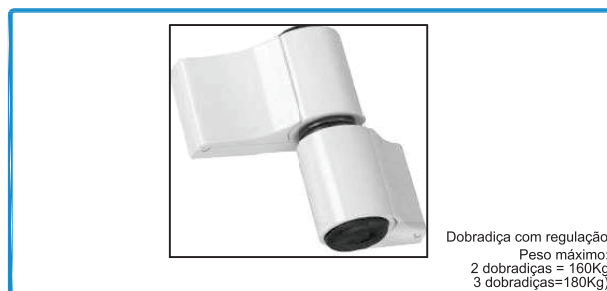

202611

DOBRADIÇA 2 ABAS 1146.1/62.5

Dobradiça com regulação
Peso máximo:
2 dobradiças = 160Kg
3 dobradiças = 180Kg

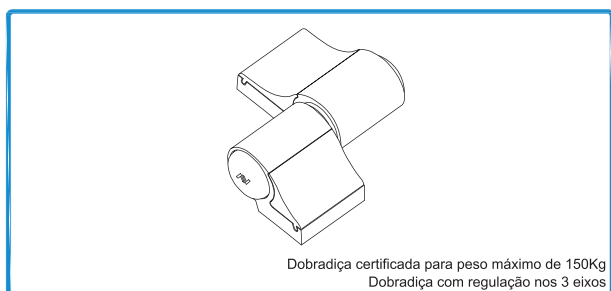

202010
202012
202020

DOBRADIÇA MECÂNICA 2 ABAS 1145/60
DOBRADIÇA MECÂNICA 2 ABAS 1145/79
DOBRADIÇA MECÂNICA 2 ABAS 1145/93SM

Dobradiça certificada para peso máximo de 150Kg
Dobradiça com regulação nos 3 eixos

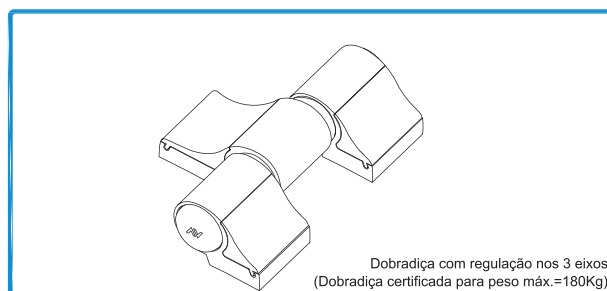

202610

DOBRADIÇA MECÂNICA 3 ABAS 1145.3/60

Dobradiça com regulação nos 3 eixos
(Dobradiça certificada para peso máx.=180Kg)

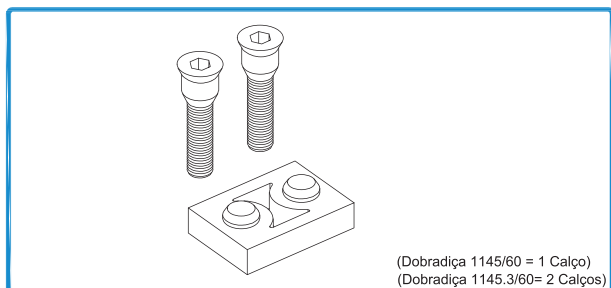

218170

CALÇO PARA DOBRADIÇA MECÂNICA 1145.703/7

(Dobradiça 1145/60 = 1 Calço)
(Dobradiça 1145.3/60 = 2 Calços)

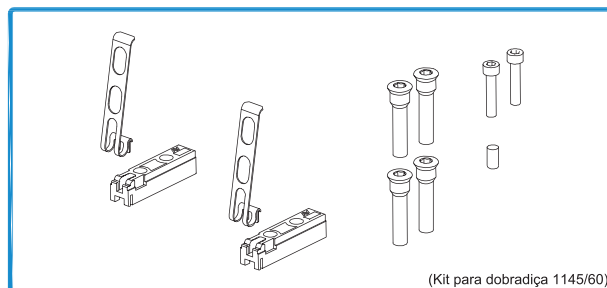

223100

KIT DE FIXAÇÃO PARA MECÂNICA 1145.705

(Kit para dobradiça 1145/60)

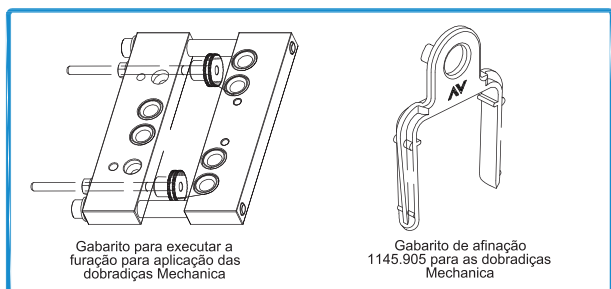

211101

GABARITO PARA FURAÇÃO 1145.908

Gabarito para executar a furação para aplicação das dobradiças Mecânica

Gabarito de afinação 1145.905 para as dobradiças Mecânica

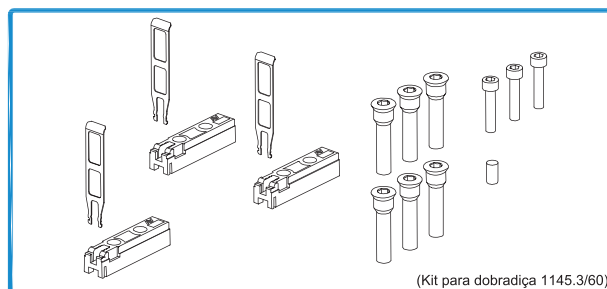

223020

KIT DE FIXAÇÃO PARA MECÂNICA 1145.715

(Kit para dobradiça 1145.3/60)



202352 DOBRADIÇA INOX 100Kg

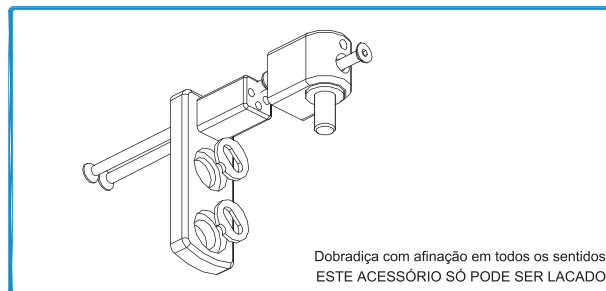

202164 DOBRADIÇA COM REGULAÇÃO PA 24000

Dobradiça com afinação em todos os sentidos
ESTE ACESSÓRIO SÓ PODE SER LACADO

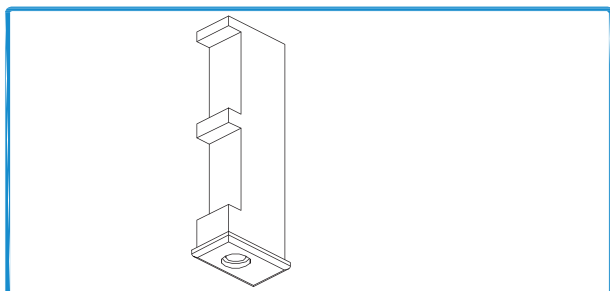

215143 PEÇA PARA DOBRADIÇAS PA17131 Br e PA17132 Pr.

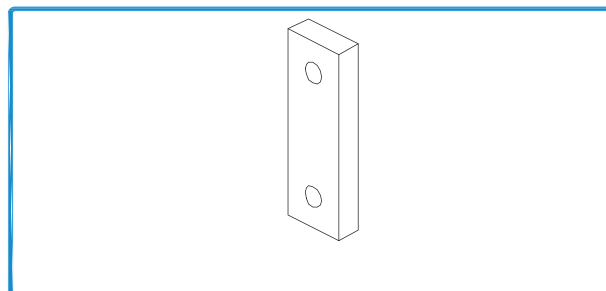

215175 PLACA DE REFORÇO PARA DOBRADIÇA 24000



227124 PIVOT SUPERIOR INOX

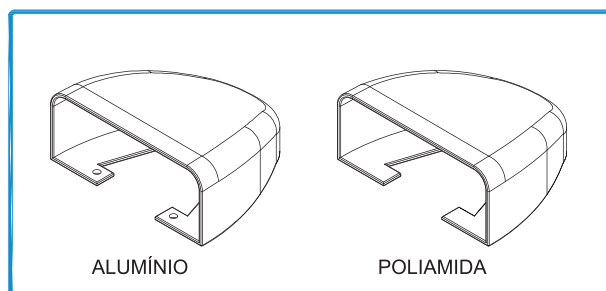

207332 TAMPA EM ALUMÍNIO PARA PIVOT SUPERIOR INOX
207333 TAMPA EM POLIAMIDA PARA PIVOT SUPERIOR INOX

ALUMÍNIO

POLIAMIDA



227127 PIVOT SUPERIOR Nº 2 INOX C/ CAPA EM POLIAMIDA

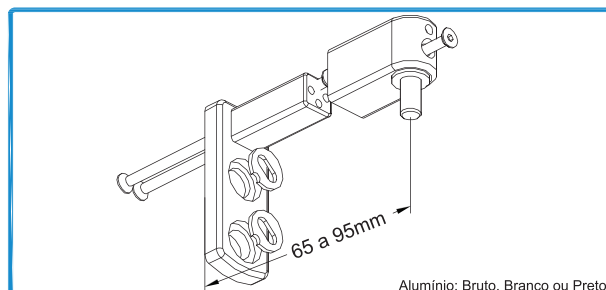

227123 PIVOT SUPERIOR Nº3 65/95mm ALUMÍNIO

65 a 95mm

Alumínio: Bruto, Branco ou Preto



210180 ANEL PIVOT Nº 2 (LATÃO)



210181 ANEL PIVOT Nº 3 (POLIAMIDA)

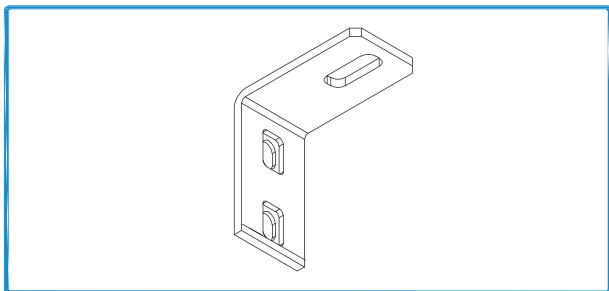

227119
227120

PIVOT SUP./INF. Nº 1 INOX
PIVOT SUP./INF. Nº 1 GALVANIZADO

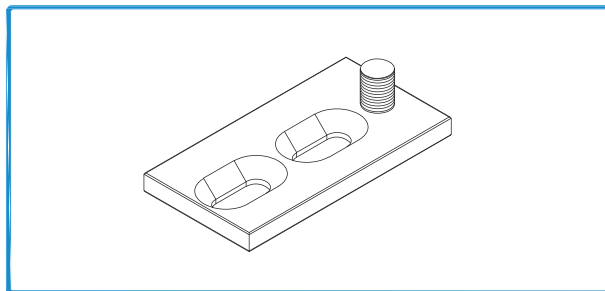

227121
227122

PIVOT INFERIOR Nº 1 INOX
PIVOT INFERIOR Nº 1 GALVANIZADO



227125

PIVOT INFERIOR Nº 2 INOX



227126

PIVOT INFERIOR Nº 3 INOX

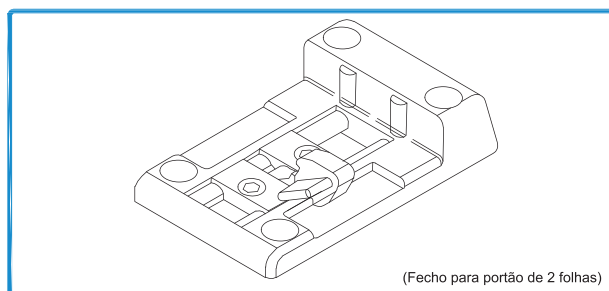

201570

FECHO INFERIOR PVC PARA 2 FOLHAS PA 16201 Pr.

(Fecho para portão de 2 folhas)

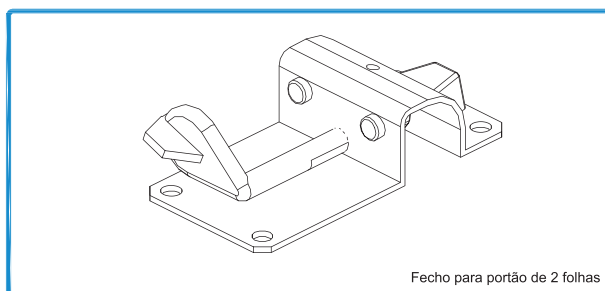

201025

FECHO INFERIOR INOX PARA 2 FOLHAS PA 16011

Fecho para portão de 2 folhas

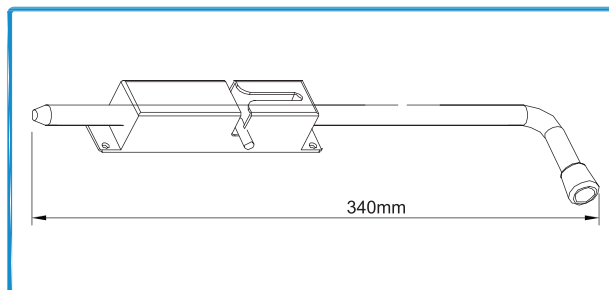

201424

FECHO CULATRA 16064 INOX

340mm



212915

CONJUNTO UNIÃO P/MONTANTE RA 857

União para ligação dos montantes com inclinação variável

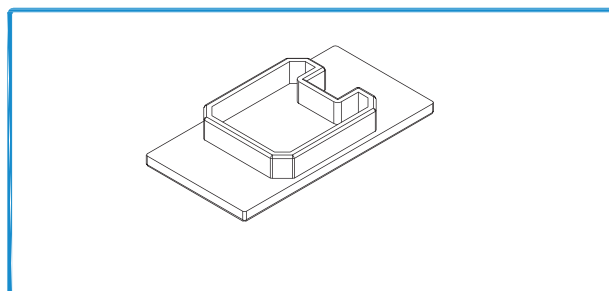

210039

TOPO SIMPLES PARA PT231

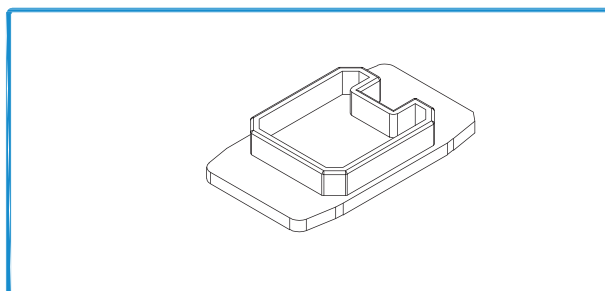

210040

TOPO SIMPLES PARA PT241

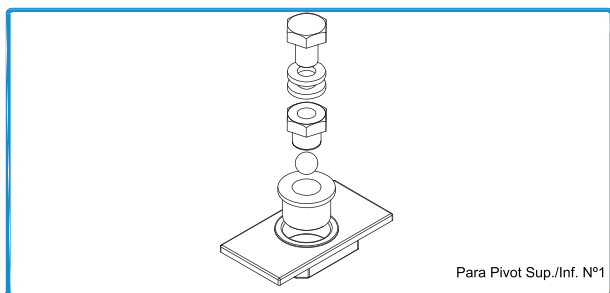

210042 TOPO PIVOT SUPERIOR Nº2 PARA PT231

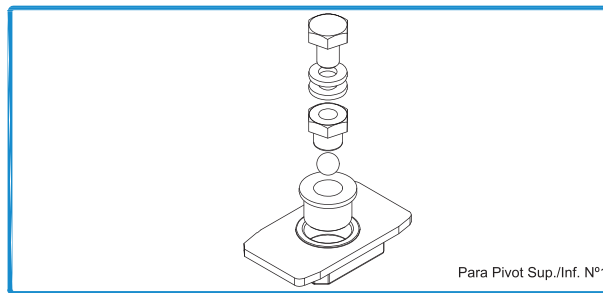

210045 TOPO PIVOT SUPERIOR Nº5 PARA PT241

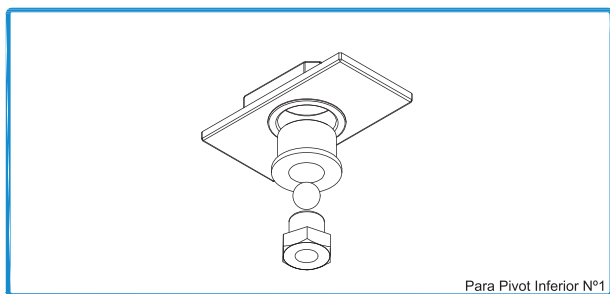

210041 TOPO PIVOT INFERIOR Nº1 PARA PT231

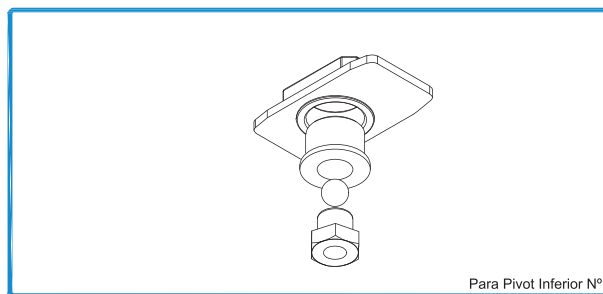

210044 TOPO PIVOT INFERIOR Nº4 PARA PT241

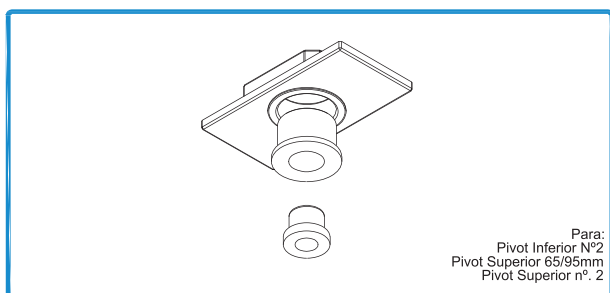

210043 TOPO PIVOT Nº3 PARA PT231

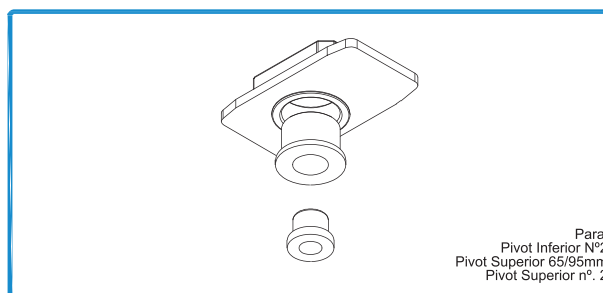

210046 TOPO PIVOT Nº6 PARA PT241

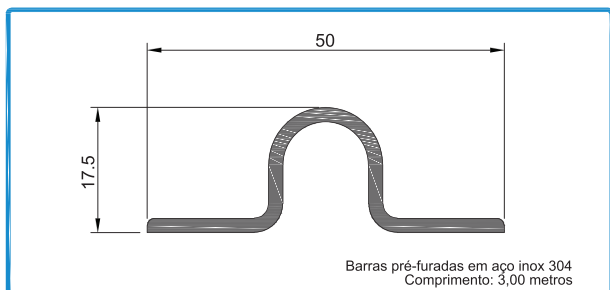

207136 GUIA INOX PT 20049 (3m)

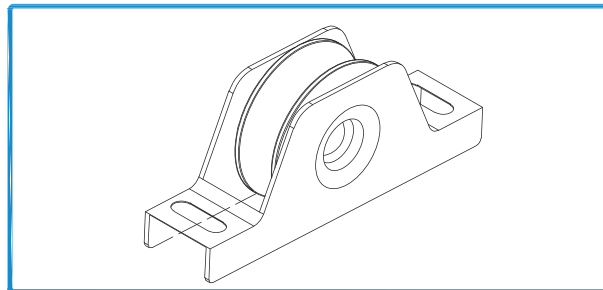

207280 ROLAMENTO PT Nº3 INOX
207281 ROLAMENTO PA Nº4 AÇO GALVANIZADO

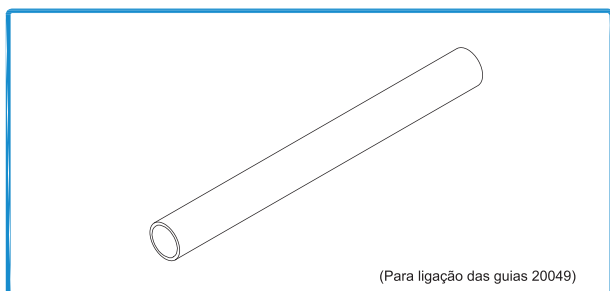

232009 UNIÃO PARA GUIA INOX 20052

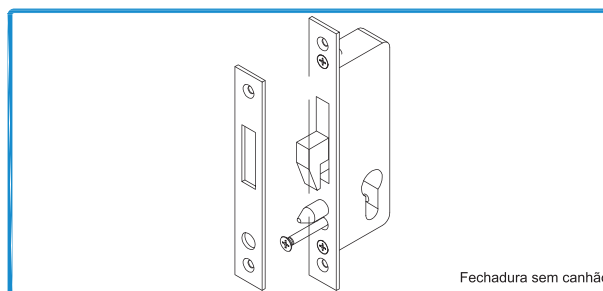

201038 FECHADURA DE GANCHO SEM CIL. 9796

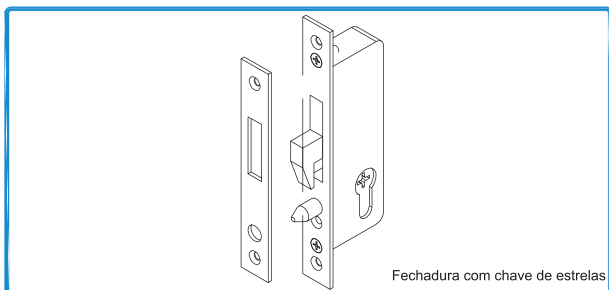

Fechadura com chave de estrelas

201039

FECHADURA DE GANCHO 9796/S

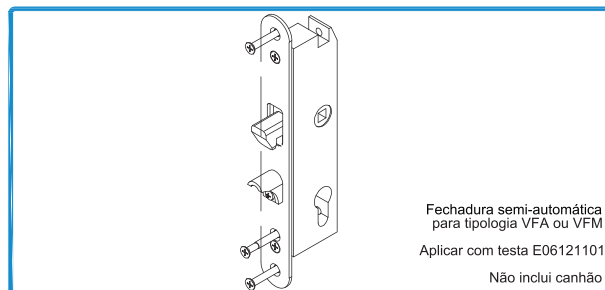

Fechadura semi-automática para tipologia VFA ou VFM
Aplicar com testa E06121101
Não inclui canhão

201614

FECHADURA PRUMO 11552

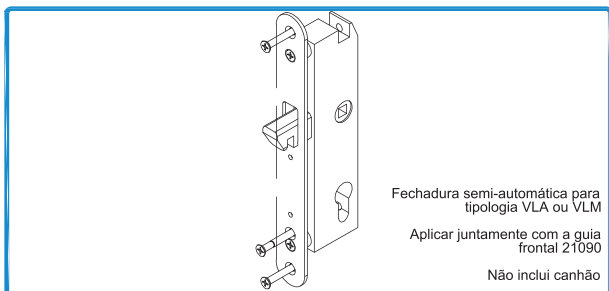

Fechadura semi-automática para tipologia VLA ou VLM
Aplicar juntamente com a guia frontal 21090
Não inclui canhão

201613

FECHADURA PRUMO 11553 PGR

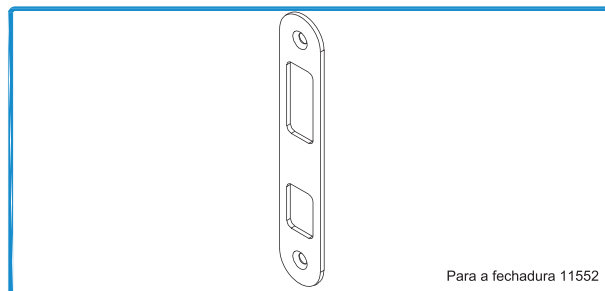

Para a fechadura 11552

280243

TESTA PARA FECHADURA E06121101

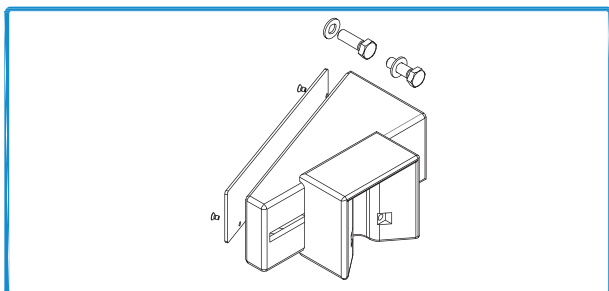

201813

FECHO LATERAL REG. 21060

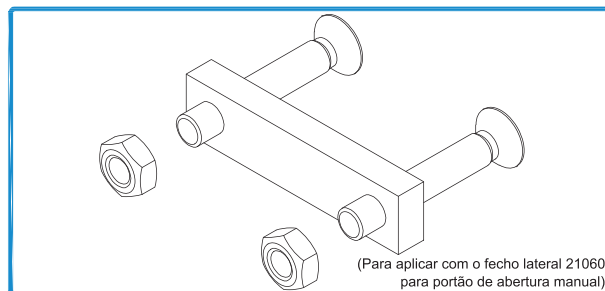

(Para aplicar com o fecho lateral 21060 para portão de abertura manual)

202100

CONTRA-FECHO INOX 21080

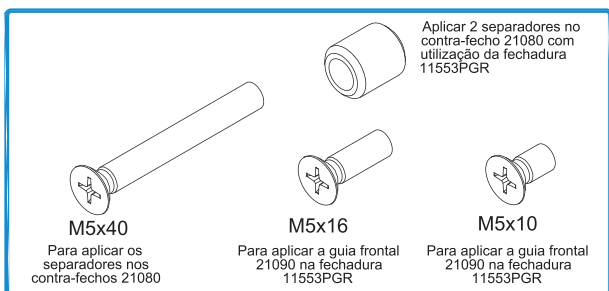

M5x40

Para aplicar os separadores nos contra-fechos 21080

M5x16

Para aplicar a guia frontal 21090 na fechadura 11553PGR

M5x10

Para aplicar a guia frontal 21090 na fechadura 11553PGR

Aplicar 2 separadores no contra-fecho 21080 com utilização da fechadura 11553PGR

210012

SEPARADOR 714

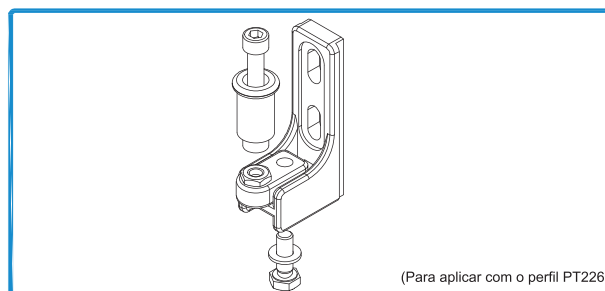

(Para aplicar com o perfil PT226)

207508

GUIA REGULÁVEL 21010

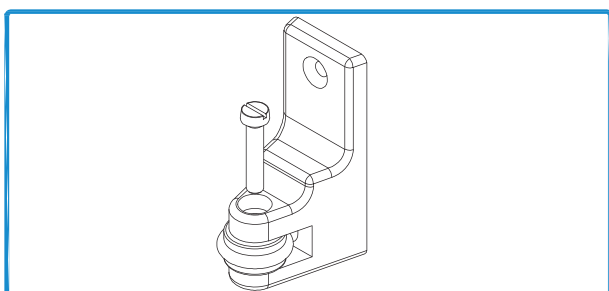

207138

GUIA FRONTAL 21090

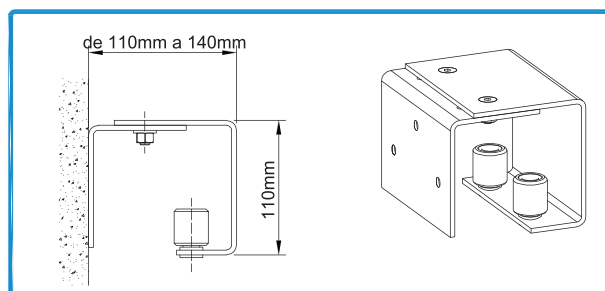

223053
223054

KIT GUIAS DE CORRER INOX
KIT GUIAS DE CORRER ALUMINIO

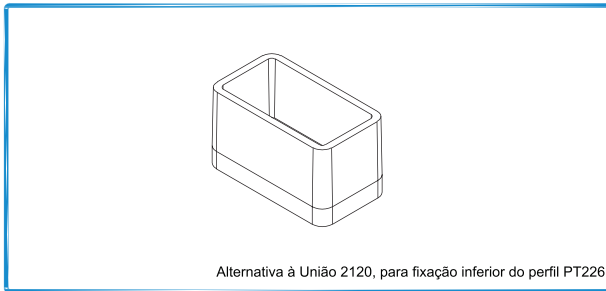

Alternativa à União 2120, para fixação inferior do perfil PT226

232012

UNIÃO PT 18153

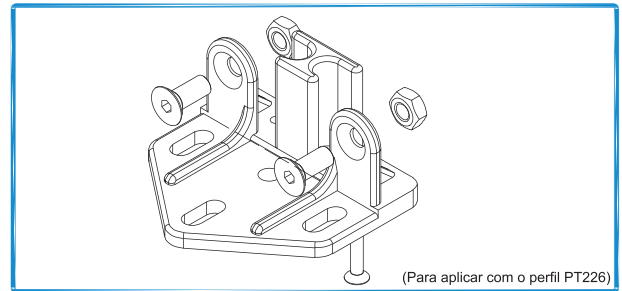

(Para aplicar com o perfil PT226)

232011

UNIÃO 21020

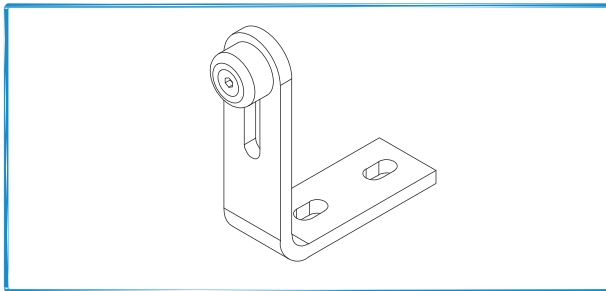

214029
214028

BATENTE PA Nº1 INOX
BATENTE PT Nº2 GALVANIZADO

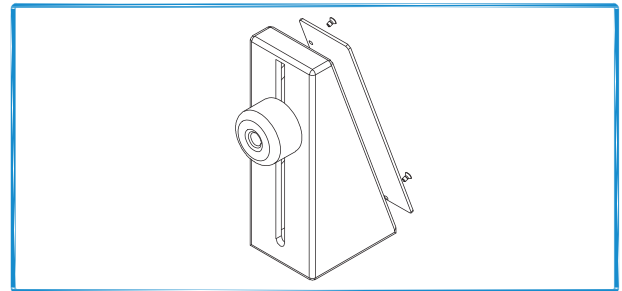

214021

BATENTE CORRER 21110

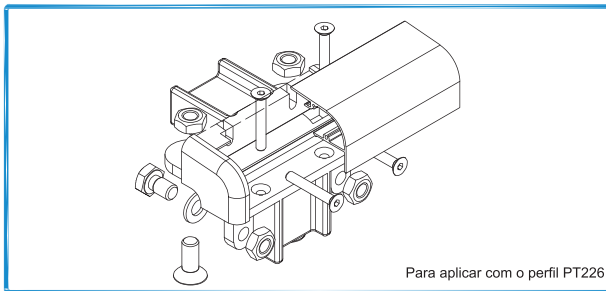

Para aplicar com o perfil PT226

213012

CANTO 21030

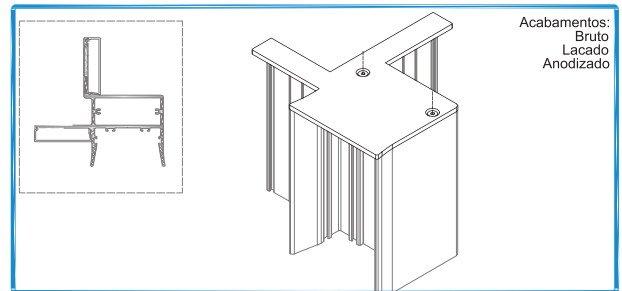

Acabamentos:
Bruto
Lacado
Anodizado

210038

TOPO PARA PT266

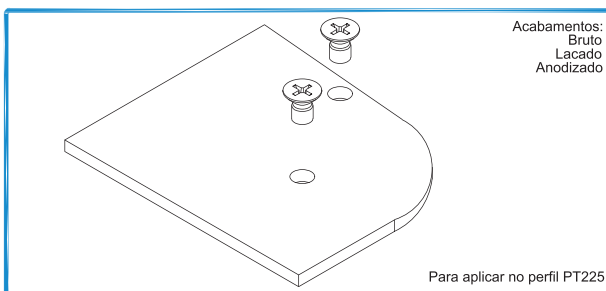

Acabamentos:
Bruto
Lacado
Anodizado

Para aplicar no perfil PT225

210033

TOPO-GUIA 21042

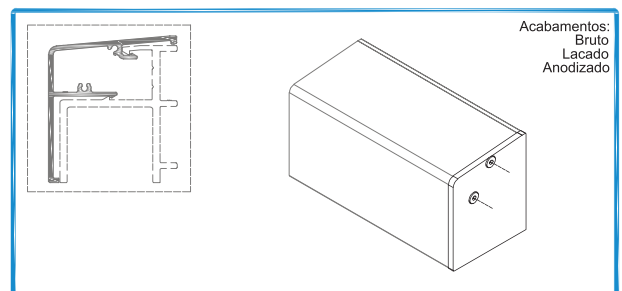

Acabamentos:
Bruto
Lacado
Anodizado

210037

TOPO PARA PT265

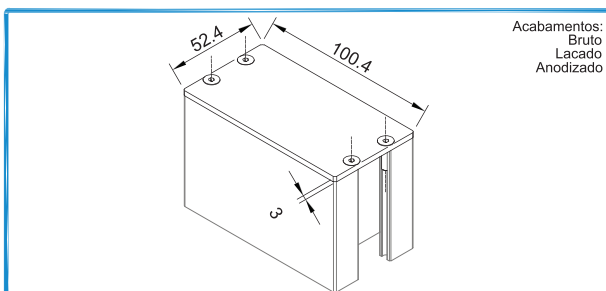

Acabamentos:
Bruto
Lacado
Anodizado

210008

TOPO PARA PT231

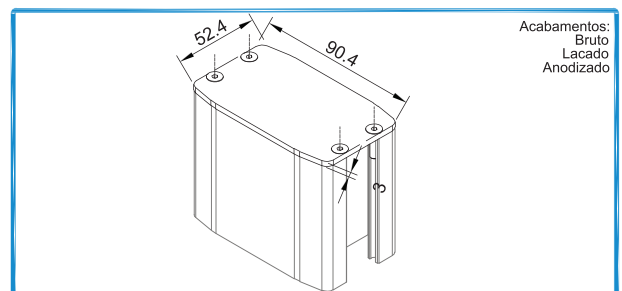

Acabamentos:
Bruto
Lacado
Anodizado

210036

TOPO PARA PT241

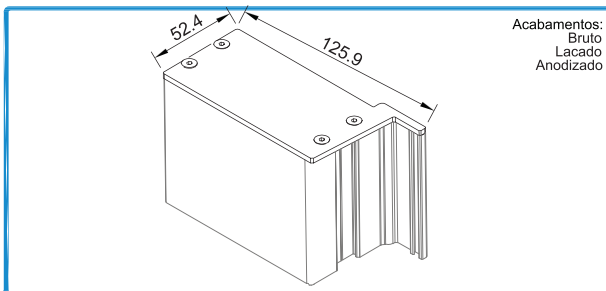

Acabamentos:
Bruto
Lacado
Anodizado

210034

TOPO PARA PT237

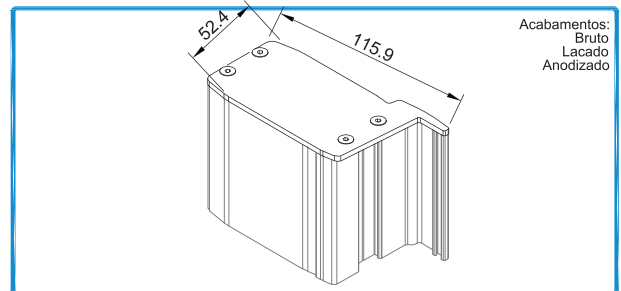

Acabamentos:
Bruto
Lacado
Anodizado

210007

TOPO PARA PT230

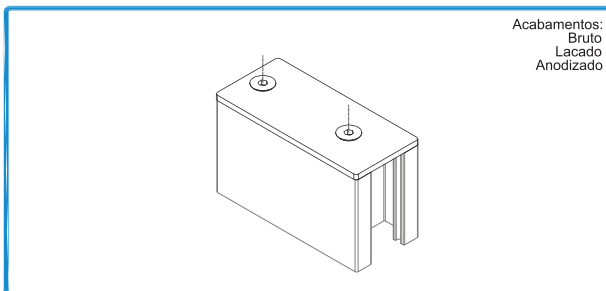

Acabamentos:
Bruto
Lacado
Anodizado

210009

TOPO PARA PT234

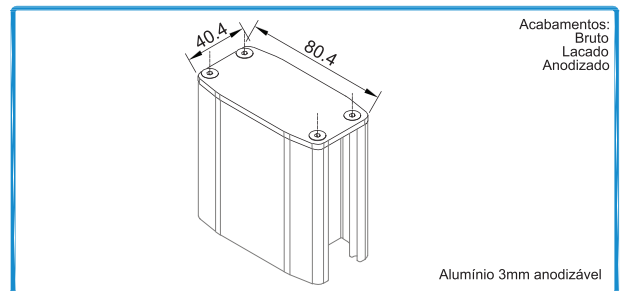

Acabamentos:
Bruto
Lacado
Anodizado

Alumínio 3mm anodizável

210052

TOPO PARA PT242

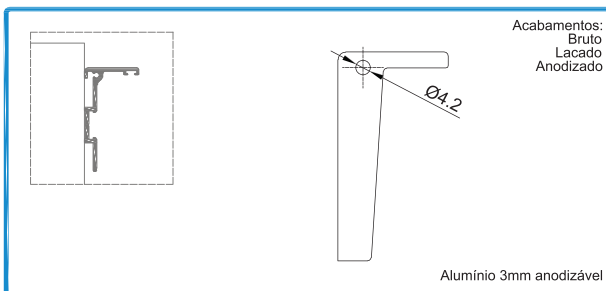

Acabamentos:
Bruto
Lacado
Anodizado

Alumínio 3mm anodizável

210049

TOPO PT237B

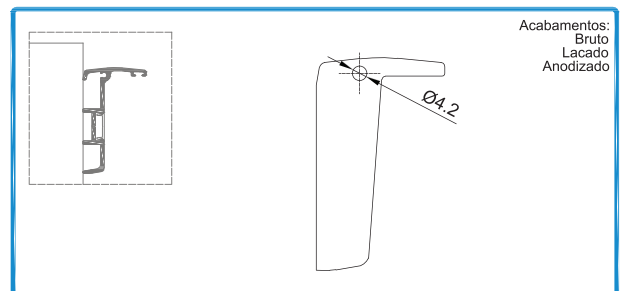

Acabamentos:
Bruto
Lacado
Anodizado

210048

TOPO PT230B

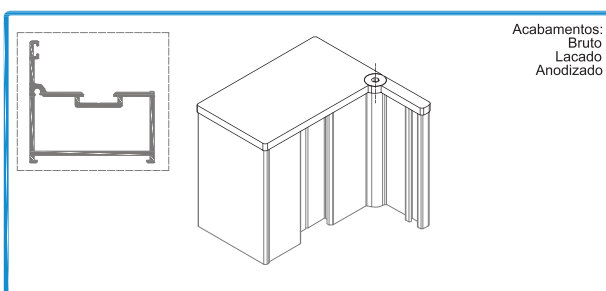

Acabamentos:
Bruto
Lacado
Anodizado

210035

TOPO PARA PT238

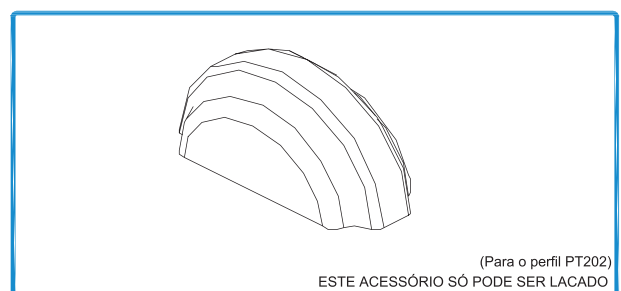

(Para o perfil PT202)
ESTE ACESSÓRIO SÓ PODE SER LACADO

210284

TOPO DECORATIVO GER-001

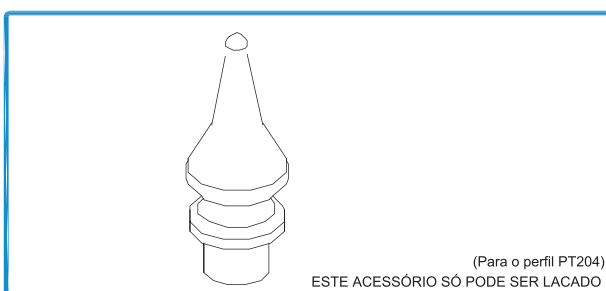

(Para o perfil PT204)
ESTE ACESSÓRIO SÓ PODE SER LACADO

210021

TOPO DECORATIVO GER-002



(Para o perfil PT204)
ESTE ACESSÓRIO SÓ PODE SER LACADO

210022

TOPO DECORATIVO GER-003

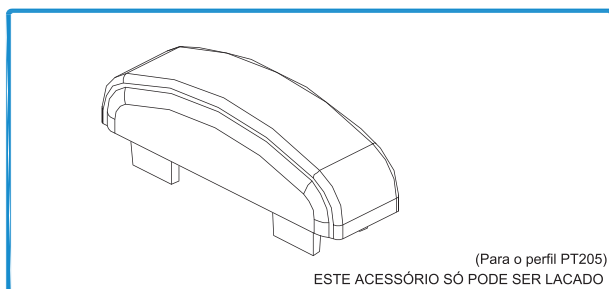

210003

TOPO PARA PT205

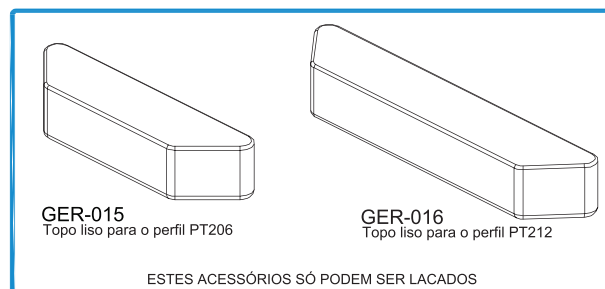

210249
210253

TOPO PT206 GER-015
TOPO PT212 GER-016

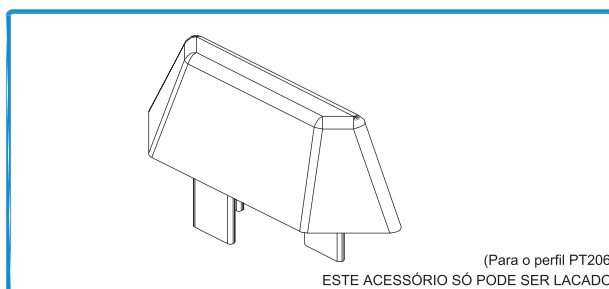

210004

TOPO PARA PT206

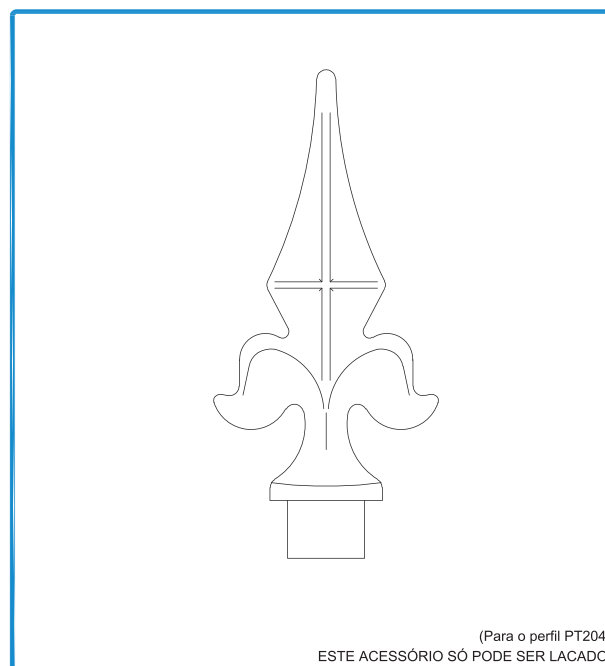

210023

TOPO DECORATIVO GER-006

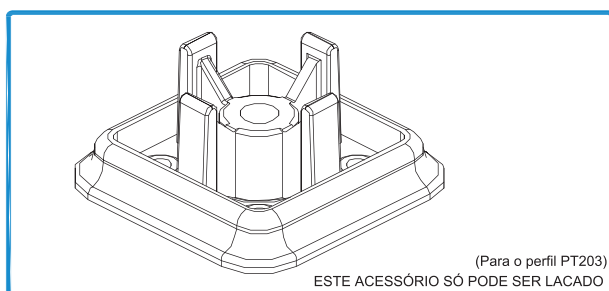

206150

PATER VERTICAL GER-004

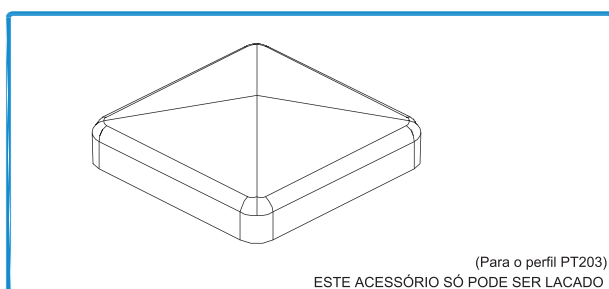

207005

TAMPA GER-005

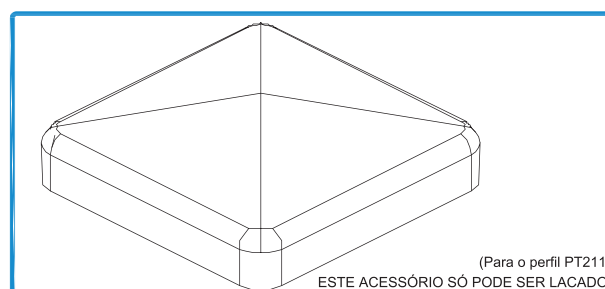

207006

TAMPA GER-008

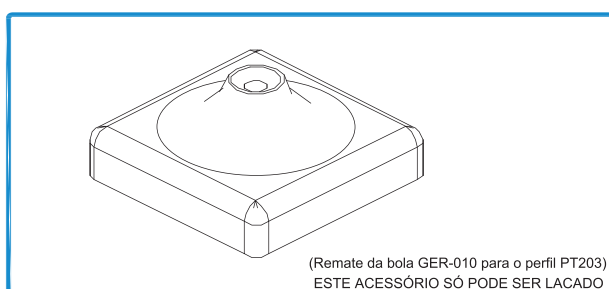

207205

REMATE PARA BOLA GER-009

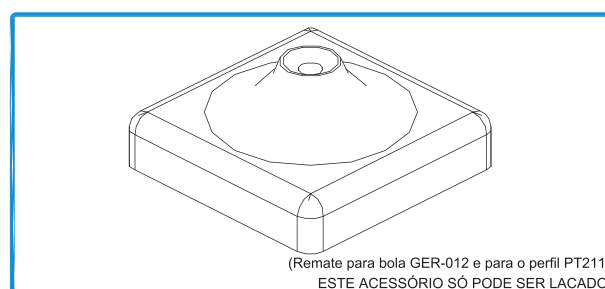

207206

REMATE PARA BOLA GER-011

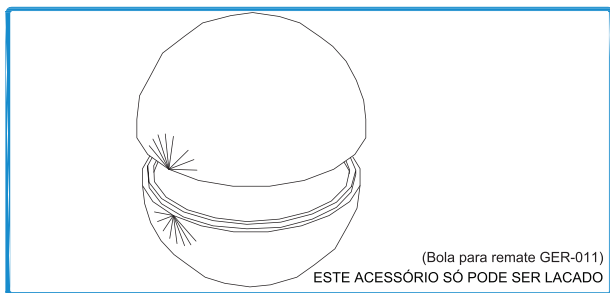

(Bola para remate GER-011)
ESTE ACESSÓRIO SÓ PODE SER LACADO

207082

BOLA 100 GER-012

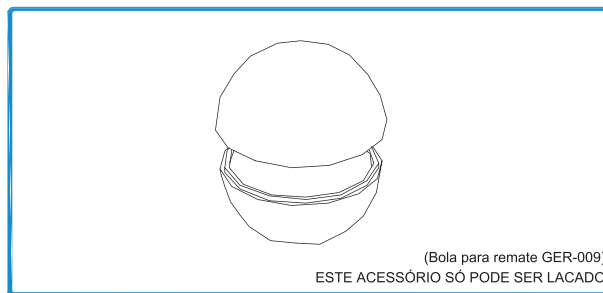

(Bola para remate GER-009)
ESTE ACESSÓRIO SÓ PODE SER LACADO

207080

BOLA 80 GER-010

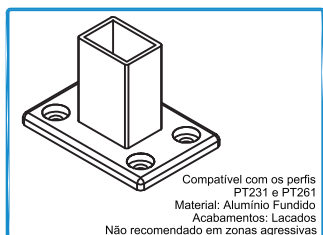

Compatível com os perfis
FT231 e FT261
Material: Alumínio Fundido
Acabamentos: Lacados
Não recomendado em zonas agressivas

299309

SAPATA FIXAÇÃO VERTICAL PT



Para fixação da Sapata Fixação Vertical PTplus
Material: Inox | Acabamento: Inox

218000

BUCHA MET. EXP. + ANILHA PT
+ PF DIN7991 M8X80 A2

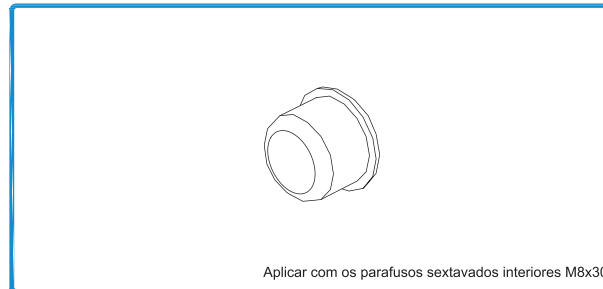

Aplicar com os parafusos sextavados interiores M8x30

210169
210015
210013

TAPA-FUROS 13mm (Br/Pr)
TAPA-FUROS 10mm (Pr)
TAPA-FUROS 10mm (Br)

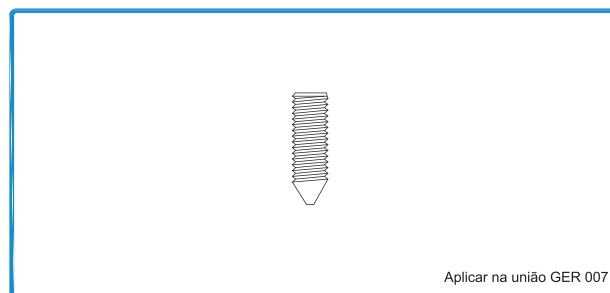

Aplicar na união GER 007

290480

PARAFUSO UMBRAKO M5x16 INOX

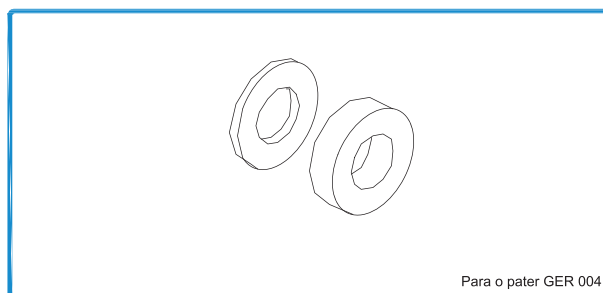

Para o pater GER 004

217104

ANILHA COLADA AN001 INOX

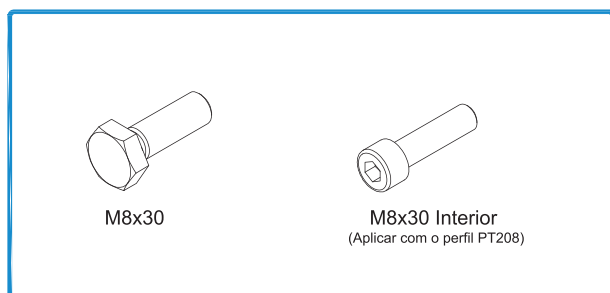

M8x30

M8x30 Interior
(Aplicar com o perfil PT208)

290454
290456

PARAFUSO SEXTAVADO M8x30 INOX
PARAFUSO SEXTAVADO INTERIOR M8x30 INOX

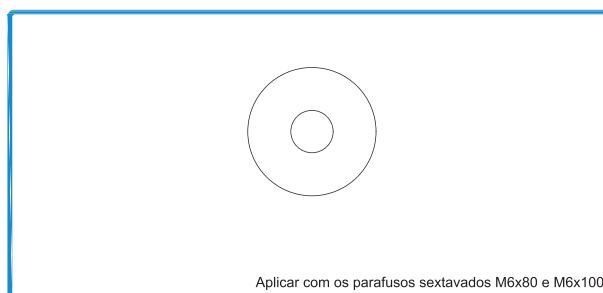

Aplicar com os parafusos sextavados M6x80 e M6x100

217114

ANILHA PLANA M6 INOX

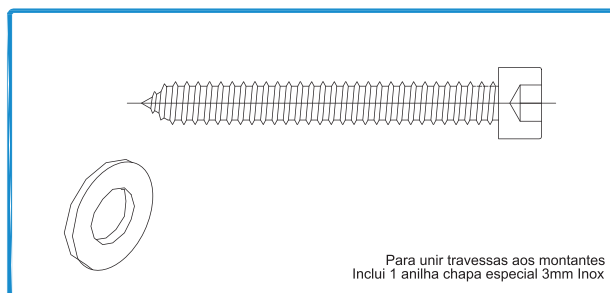

Para unir travessas aos montantes
Inclui 1 anilha chapa especial 3mm Inox

290270

PARAFUSO 6,3X50 + ANIL.CHP ESP. 6,4x17x3 INOX A2

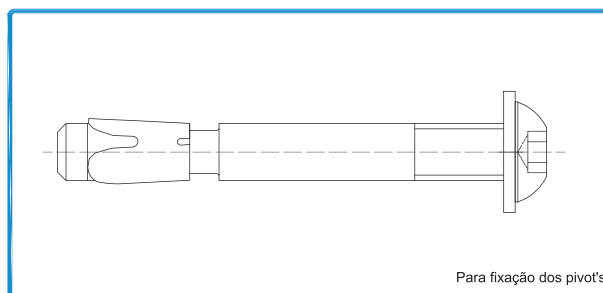

Para fixação dos pivot's

290267 PARAF. M8x60 INOX A2 C/ANILHA M8 e BUCHA METÁLICA
290268 PARAF. M10x70 INOX A2 C/ANILHA M8 e BUCHA METÁLICA

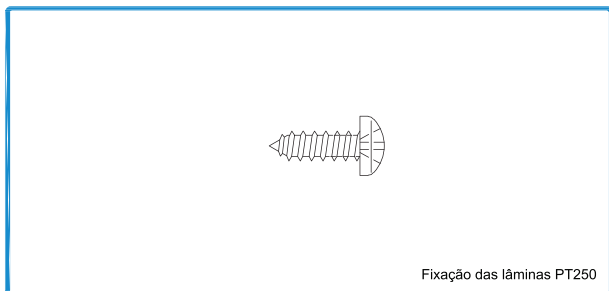

290111 PARAFUSO CQ 4,2x13 INOX A2

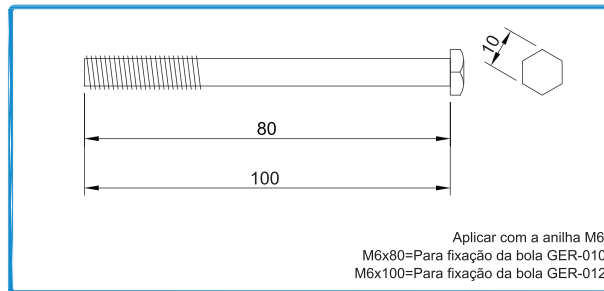

290450 PARAFUSO SEXTAVADO M6x80 INOX
290452 PARAFUSO SEXTAVADO M6x100 INOX

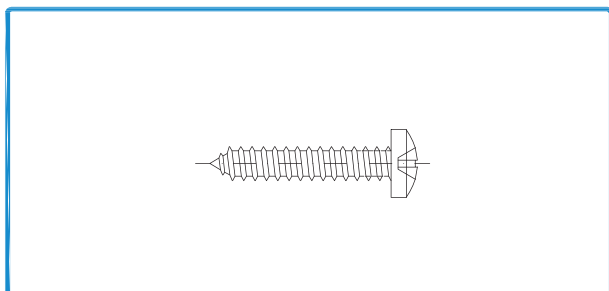

290171 PARAFUSO CQ 1x10

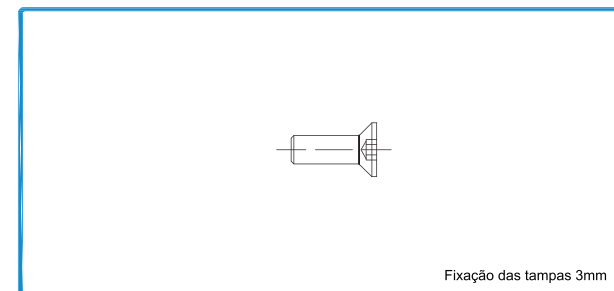

290112 PARAFUSO M4x12 INOX A2

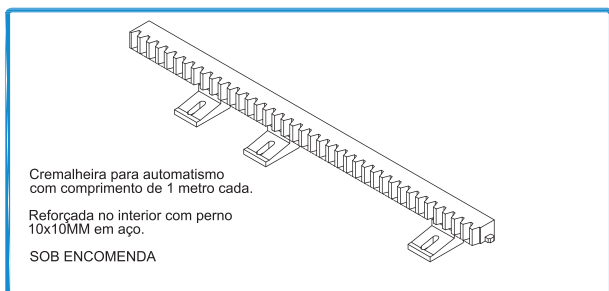

000000 CREMALHEIRA EM POLÍMERO PRETA

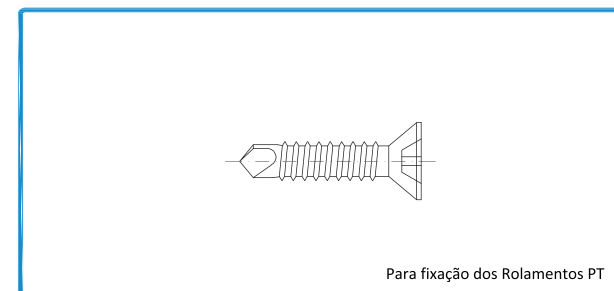

290113 PARAFUSO CX 6,3x32 INOX



208001 MASTIQUE-COLA REMAFLEX 521

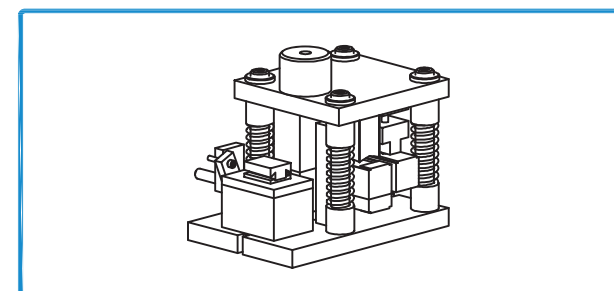

408055 CORTANTE PT+



208704 PRODUTO LIMPEZA DE ALUMÍNIO (1L) Transparente



208019 SELA JUNTAS 150gr. (Cinza)

Referência	Desenho	Designação	Observações
L30053		Dobradiças P/ Portões (Soldar)	
L30054		Dobradiças P/ Portões (Para Aparafusar)	
L40688		Tampa Aro Fixo Soldar	Aplicação PT02
L40682		Tampa Para Poste 100mm	Aplicação PT15
L40684		Tampa Para Poste 150mm	Aplicação Q21



NORTALU[®]

PORMENORES TÉCNICOS

PORTÃO DE BATENTE DE 1 e 2 FOLHAS C/ PIVOT's
LINHA RETA - COM LÂMINAS PT.250

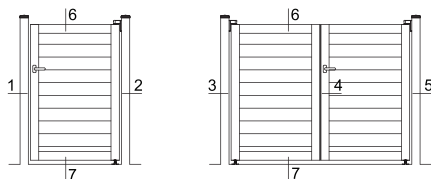

PERFIS - PORTÃO BATENTE 1 FOLHA					
REFª	DESIGNAÇÃO	CORTE HOR.	CORTE VERT.	QUANT	CORTE
PT.231	MONTANTE	-	H	2	
PT.238	ARO FIXO BATENTE	-	H+35	1	
PT.251	TAMPA	-	H	3	
PT.252	BATENTE LATERAL	-	H	1	
PT.234	TRAVESSA INF/SUP	L-116	-	2	
PT.250	LÂMINA	L-272	-	Variável	
PT.233	TRAV. CENTRAL (Op.)	L-116	-	1	
B.34	REFORÇO (Opcional)	L-116	-	1	
AT 30	TAMPA (ARO FIXO)	-	H+35	1	
PT.211	PRUMO (Opcional)	-	Opcional	2	

PERFIS - PORTÃO BATENTE 2 FOLHAS					
REFª	DESIGNAÇÃO	CORTE HOR.	CORTE VERT.	QUANT	CORTE
PT.231	MONTANTE	-	H	4	
PT.237	PERFIL BATENTE	-	H	1	
PT.251	TAMPA	-	H	5	
PT.252	BATENTE LATERAL	-	H	2	
PT.234	TRAVESSA INF/SUP	(L/2)-77	-	4	
PT.250	LÂMINA	(L/2)-233	-	Variável	
PT.233	TRAV. CENTRAL (Op.)	(L/2)-77	-	2	
B.34	REFORÇO (Opcional)	(L/2)-77	-	2	
AT 30	TAMPA (ARO MÓVEL)	-	H	1	
PT.211	PRUMO (Opcional)	-	Opcional	2	

ACESSÓRIOS			
CÓDIGO	DESIGNAÇÃO	QUANTIDADE	
		1 FOLHA	2 FOLHAS
200747	PUXADOR DUPLO 874.31	1	1
227301	QUADRA AÇO 8mm	1	1
201134	FECHADURA PRUMO PA T40	1	1
280220	TESTA PARA FECHADURA PRUMO 2000	1	1
230006	SEGREDO 30/30	1	1
201025	FECHO INF. INOX P/ 2 FOLHAS PA 16011	-	1
227119	PIVOT SUP/INF Nº.1 INOX	1*	2*
227121	PIVOT INFERIOR Nº.1 INOX	1*	2*
210042	TOPO PIVOT SUPERIOR Nº.2 PARA PT.231	1	2
210041	TOPO PIVOT INFERIOR Nº.1 PARA PT.231	1*	2*
210039	TOPO SIMPLES PARA PT.231	2	2
210035	TOPO PARA PT.238	1	-
210034	TOPO PARA PT.237	-	2
214029	BATENTE PA Nº.1 INOX	1*	2*
206150	PATER VERTICAL GER-004	2*	2*
207005	TAMPA GER-005	2*	2*
290270	PAR. 6,3x50 Inox A2 + Anilha (Para travessas)	Variável	Variável
290267	PAR. M8x60 Inox C/AN+BUC. MET.(Para pivots)	4	8
290111	PAR. CQ 4,2x13 INOX (Para Lâmina PT.250)	Variável	Variável
290112	PAR. M4x12 Inox (Para Tampas PA)	Variável	Variável

* Opcional

VEDANTES			
CÓDIGO	DESIGNAÇÃO	QUANTIDADE	
		1 FOLHA	2 FOLHAS
208008	VD 2051	1H	1H
208222	VD 2120	1H	2H
208221	VD 1033	8H	16H

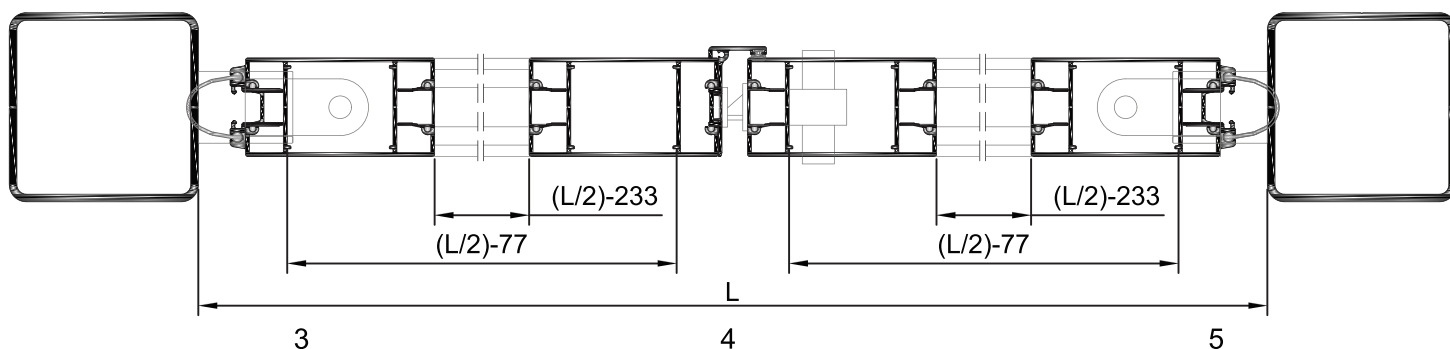
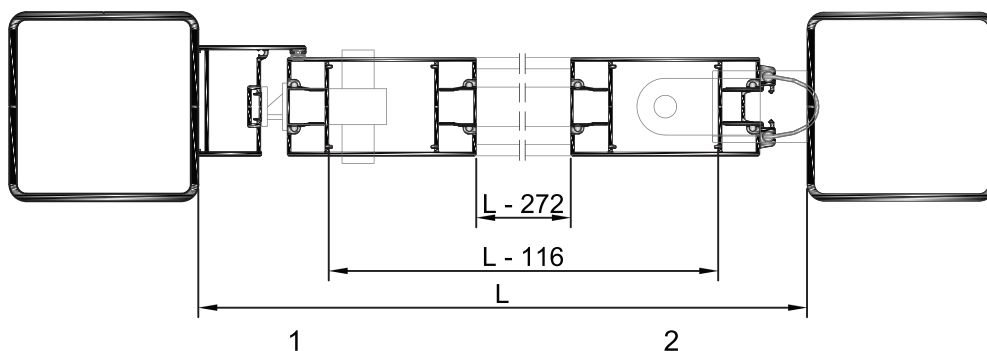
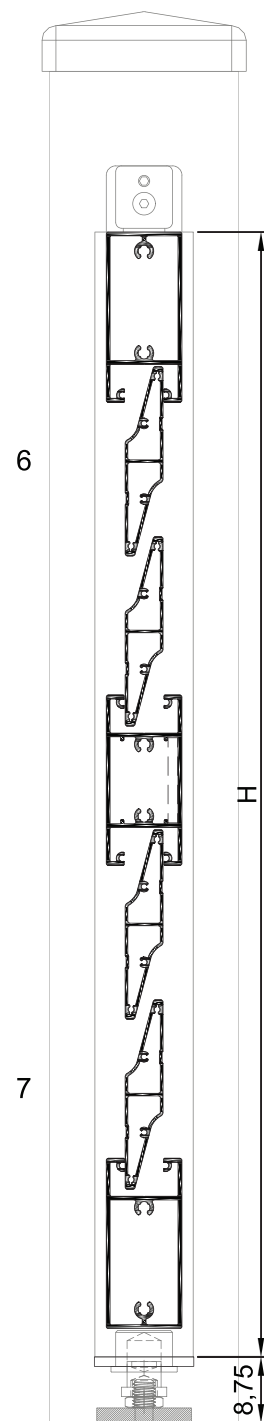

PORTÃO DE BATENTE DE 1 e 2 FOLHAS - COM DOBRADIÇAS MECHANICA LINHA RETA - COM LÂMINAS PT.250

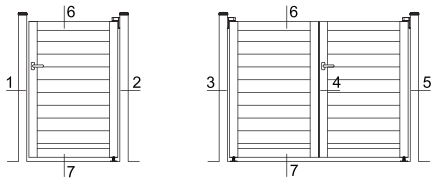

PERFIS - PORTÃO BATENTE 1 FOLHA					
REFª	DESIGNAÇÃO	CORTE HOR.	CORTE VERT.	QUANT	CORTE
PT.231	MONTANTE	-	H	2	
PT.238	ARO FIXO BATENTE	-	H+X	2	
PT.251	TAMPA	-	H	3	
PT.237	PERFIL BATENTE	-	H	1	
PT.234	TRAVESSA INF/SUP	L-136	-	2	
PT.250	LÂMINA	L-292	-	Variável	
PT.233	TRAV. CENTRAL (Op.)	L-136	-	1	
B.34	REFORÇO (Opcional)	L-136	-	1	
AT 30	TAMPA (ARO FIXO)	-	H+X	2	
AT 30	TAMPA (ARO MÓVEL)	-	H	1	

PERFIS - PORTÃO BATENTE 2 FOLHAS					
REFª	DESIGNAÇÃO	CORTE HOR.	CORTE VERT.	QUANT	CORTE
PT.231	MONTANTE	-	H	4	
PT.238	ARO FIXO BATENTE	-	H+X	2	
PT.237	PERFIL BATENTE	-	H	2	
PT.251	TAMPA	-	H	6	
PT.234	TRAVESSA INF/SUP	(L/2)-97	-	4	
PT.250	LÂMINA	(L/2)-253	-	Variável	
PT.233	TRAV. CENTRAL (Op.)	(L/2)-97	-	2	
B.34	REFORÇO (Opcional)	(L/2)-97	-	2	
AT 30	TAMPA (ARO FIXO)	-	H+X	2	
AT 30	TAMPA (ARO MÓVEL)	-	H	2	

ACESSÓRIOS			
CÓDIGO	DESIGNAÇÃO	QUANTIDADE	
		1 FOLHA	2 FOLHAS
200747	PUXADOR DUPLO 874.31	1	1
227301	QUADRA AÇO 8mm	1	1
201134	FECHADURA PRUMO PA T40	1	1
280220	TESTA PARA FECHADURA PRUMO 2000	1	1
230006	SEGREDO 30/30	1	1
202611	DOBRADIÇA MECHANICA 2 ABAS 1146.1/62.5	2*	4*
223100	KIT FIXAÇÃO PARA MECHANICA 1145.705	2*	4*
214029	BATENTE PA Nº.1 INOX	1*	2*
210008	TOPO PARA PT.231	2	4
210035	TOPO PARA PT.238	2	2
210034	TOPO PARA PT.237	2	4
201025	FECHO INF. INOX P/ 2 FOLHAS PA 16011	-	1
290270	PARAFUSO 6,3x50 INOX A2 + ANILHA	Variável	Variável
290111	PAR. CQ 4,2x13 INOX (Para Lâmina PT.250)	Variável	Variável
290112	PAR. M4x12 Inox (Para Tampas PA)	Variável	Variável

* Opcional

VEDANTES			
CÓDIGO	DESIGNAÇÃO	QUANTIDADE	
		1 FOLHA	2 FOLHAS
208008	VD 2051	3H	4H
208221	VD 1033	8H	16H

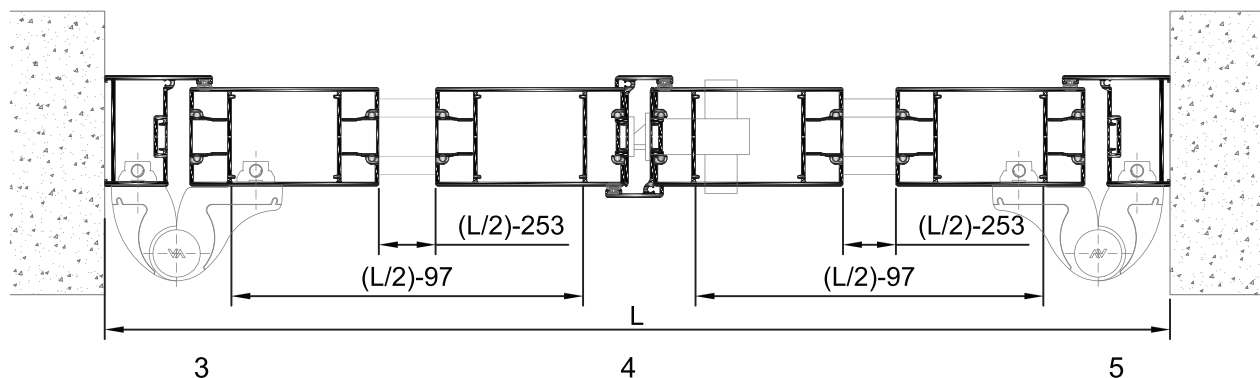
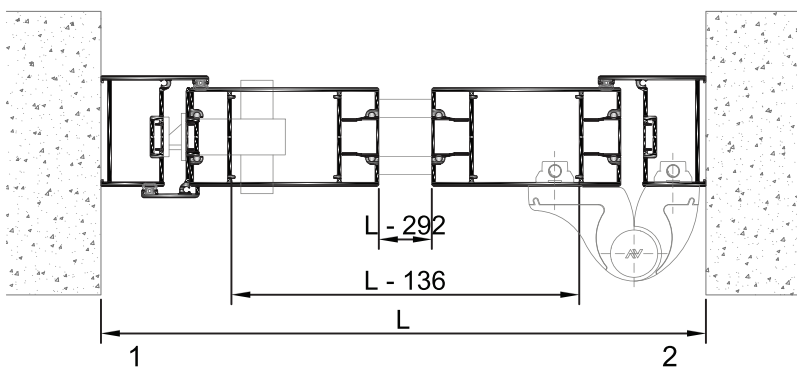
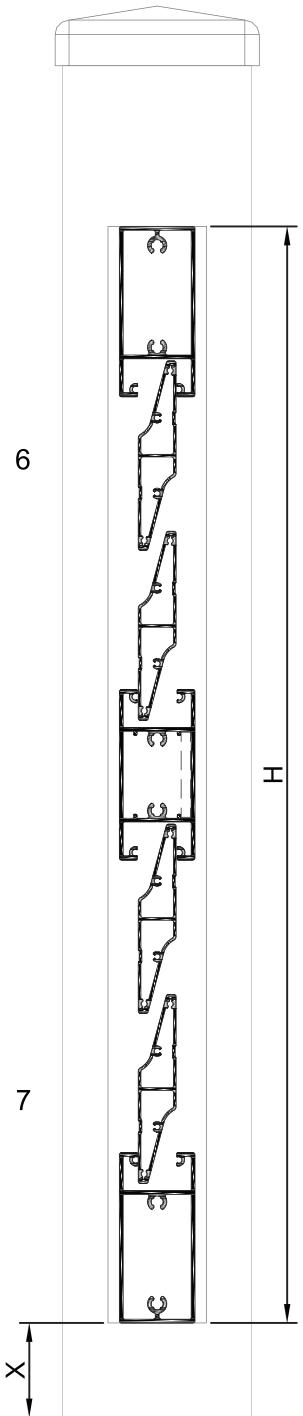

PORTÃO DE BATENTE DE 1 e 2 FOLHAS - COM DOBRADIÇA 100Kg - 180°
LINHA RETA - COM LÂMINAS PT.250

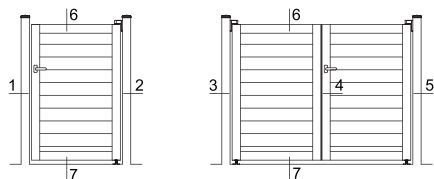

PERFIS - PORTÃO BATENTE 1 FOLHA					
REF ^a	DESIGNAÇÃO	CORTE HOR.	CORTE VERT.	QUANT	CORTE
PT.231	MONTANTE	-	H	2	
PT.251	TAMPA	-	H	4	
PT.237	PERFIL PAREDE	-	H+X	2	
PT.234	TRAVESSA INF/SUP	L-83	-	2	
PT.250	LÂMINA	L-239	-	Variável	
PT.233	TRAV. CENTRAL (Op.)	L-83	-	1	
B.34	REFORÇO (Opcional)	L-83	-	1	
AT 30	TAMPA (ARO FIXO)	-	H+X	2	

PERFIS - PORTÃO BATENTE 2 FOLHAS					
REF ^a	DESIGNAÇÃO	CORTE HOR.	CORTE VERT.	QUANT	CORTE
PT.231	MONTANTE	-	H	4	
PT.237	ARO FIXO BATENTE	-	H+X	2	
PT.237	PERFIL BATENTE	-	H	2	
PT.251	TAMPA	-	H	6	
PT.234	TRAVESSA INF/SUP	(L/2)-70	-	4	
PT.250	LÂMINA	(L/2)-226	-	Variável	
PT.233	TRAV. CENTRAL (Op.)	(L/2)-70	-	2	
B.34	REFORÇO (Opcional)	(L/2)-70	-	2	
AT 30	TAMPA (ARO FIXO)	-	H+X	2	
AT 30	TAMPA (ARO MÓVEL)	-	H	2	

ACESSÓRIOS			
CÓDIGO	DESIGNAÇÃO	QUANTIDADE	
		1 FOLHA	2 FOLHAS
200747	PUXADOR DUPLO 874	1	1
227301	QUADRA AÇO 8mm	1	1
201134	FECHADURA PRUMO PA T40	1	1
280220	TESTA PARA FECHADURA PRUMO 2000	1	1
230006	SEGREDO 30/30	1	1
202010	DOBRADIÇA INOX 100Kg	2	4
214029	BATENTE PA Nº.1 INOX	1*	2*
210008	TOPO PARA PT.231	4	4
210034	TOPO PARA PT.237	-	4
210049	TOPO PARA PT.237B	2	2
201025	FECHO INF. INOX P/ 2 FOLHAS PA 16011	-	1
290270	PARAFUSO 6,3x50 INOX A2 + ANILHA	Variável	Variável
290111	PAR. CQ 4,2x13 INOX (Para Lâmina PT.250)	Variável	Variável
290112	PAR. M4x12 Inox (Para Tampas PT)	Variável	Variável

* Opcional

VEDANTES			
CÓDIGO	DESIGNAÇÃO	QUANTIDADE	
		1 FOLHA	2 FOLHAS
208008	VD 2051	2H	4H
208221	VD 1033	8H	16H

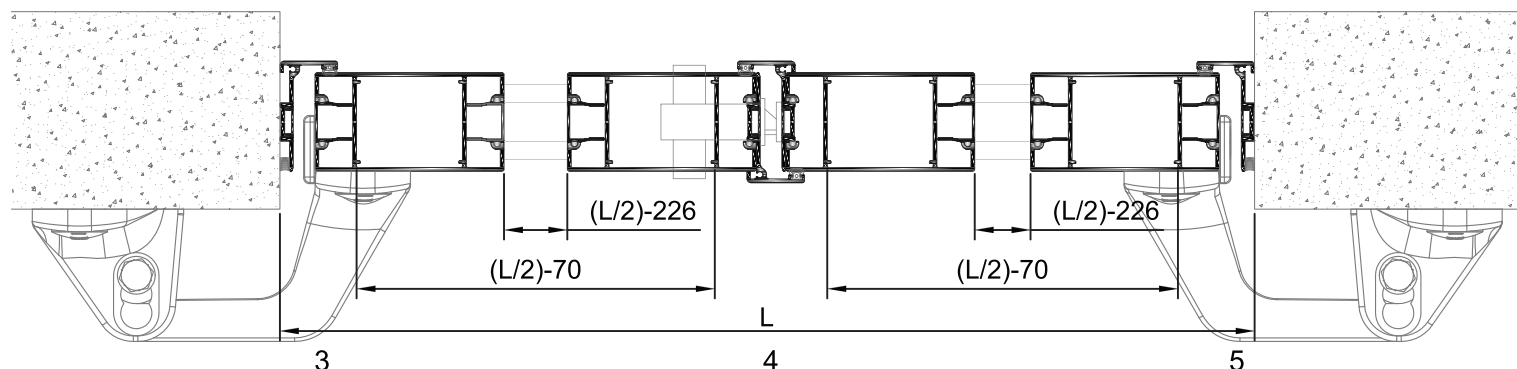
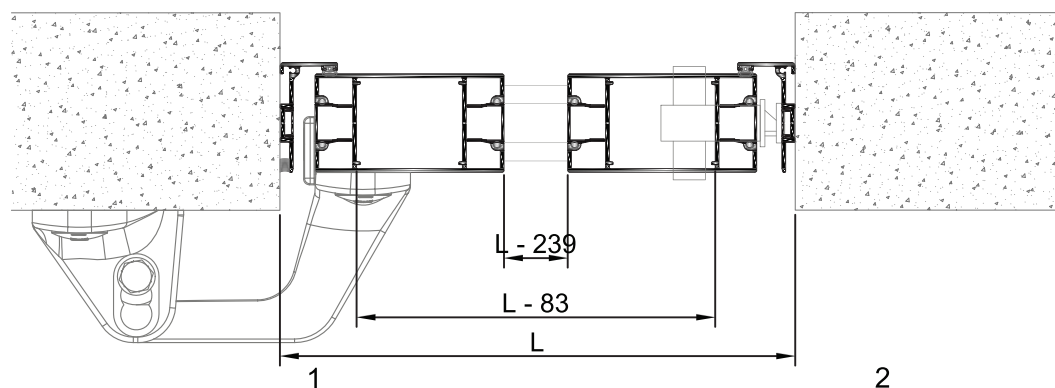
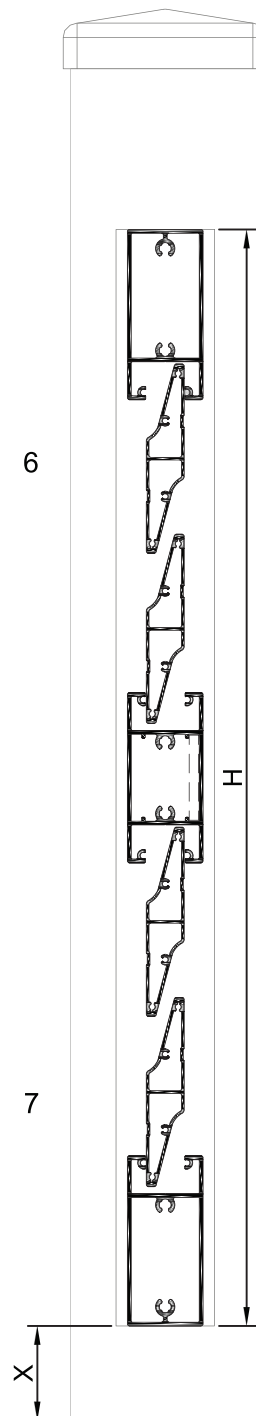

PORTÃO DE CORRER COM GUIA PT.265 LINHA RETA

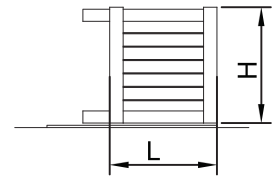

PERFIS - PORTÃO CORRER COM LÂMINA PA 50					
REFª	DESIGNAÇÃO	CORTE HOR.	CORTE VERT.	QUANT	CORTE
PT.231	MONTANTE	-	H	2	
PT.266	ARO FIXO BATENTE	-	H+28	1	
PT.267	TAMPA	-	H+28	2	
PT.251	TAMPA	-	H	4	
PT.234	TRAVESSA INF/SUP	LP+178	-	2	
PT.250	LÂMINA	LP-200	-	Variável	
PT.233	TRAV. CENTRAL (Op.)	LP-44	-	1	
PT.265	GUIA SUP CORRER	LP+97	-	1	
PT.264	GUIA SUP CORRER	LP+97	-	1	

PERFIS - PORTÃO CORRER COM LÂMINA KW 92 ou KW 82					
REFª	DESIGNAÇÃO	CORTE HOR.	CORTE VERT.	QUANT	CORTE
PT.231	MONTANTE	-	H	2	
PT.266	ARO FIXO BATENTE	-	H+28	1	
PT.267	TAMPA	-	H+28	2	
PT.251	TAMPA	-	H	2	
PT.234	TRAVESSA INF/SUP	LP+178	-	2	
W.31 ou W.36	LÂMINA	LP-160	-	Variável	
PT.233	TRAV. CENTRAL (Op.)	LP-44	-	1	
PT.265	GUIA SUP CORRER	LP+97	-	1	
PT.264	GUIA SUP CORRER	LP+97	-	1	

ACESSÓRIOS		
CÓDIGO	DESIGNAÇÃO	QUANTIDADE
200747	PUXADOR DUPLO 874.31	1*
227301	QUADRA AÇO 8mm	1*
201614	FECHADURA PRUMO 11552	1*
280243	TESTA PARA FECHADURA E06121101	1*
230006	SEGREDO 30/30 CHAV NIQUELADO	1*
207136	GUIA INOX PA 20049 (3m)	Lx2
232009	UNIÃO PARA GUIA INOX 20052	1**
207280	ROLAMENTO PA Nº.3 INOX	2*
223053	KIT GUIAS DE CORRER INOX	1*
214029	BATENTE PA Nº.1 INOX	1*
210008	TOPO PARA PT.231	4
210009	TOPO PARA PT.234	2
210038	TOPO PARA PT.266	1
210037	TOPO PARA PT.265	2
290270	PAR 6,3x50 Inox A2 + ANILHA (Para travessas)	Variável
290267	PAR. M8x60 Inox C/AN+BUC. MET.(Para guias)	3
290111	PAR. CQ 4,2x13 INOX (Para Lâmina PT.250)	Variável
290112	PAR. M4x12 Inox (Para Tampas PT)	Variável
290113	PARAFUSO CX 6,3x32 INOX	4

* Opcional ** Para guias superiores a 3,00m

VEDANTES			
CÓDIGO	DESIGNAÇÃO	QUANTIDADE	
208008	VD 2051	2H	
208564	VEDANTE PELÚCIA 4,8X7	2H	
208221	VD 1033	COM PA 50	8H
		COM KW 82 ou 92	4L+8H

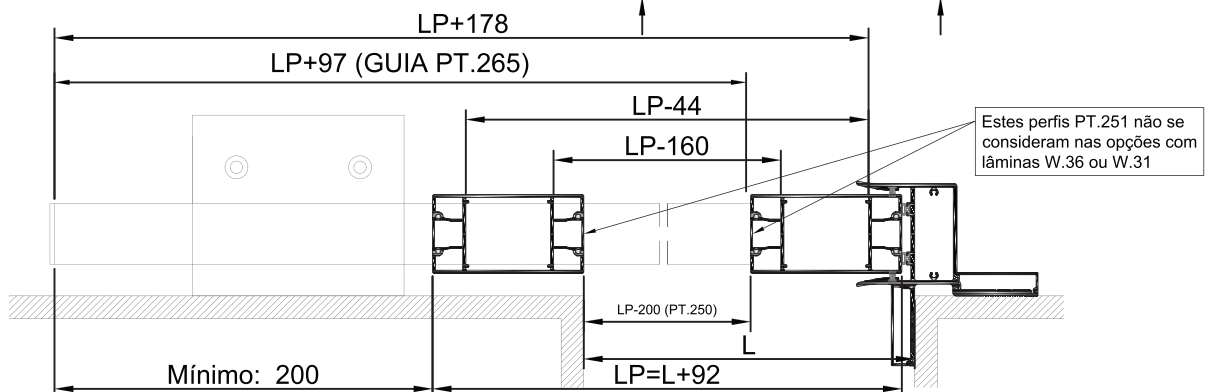
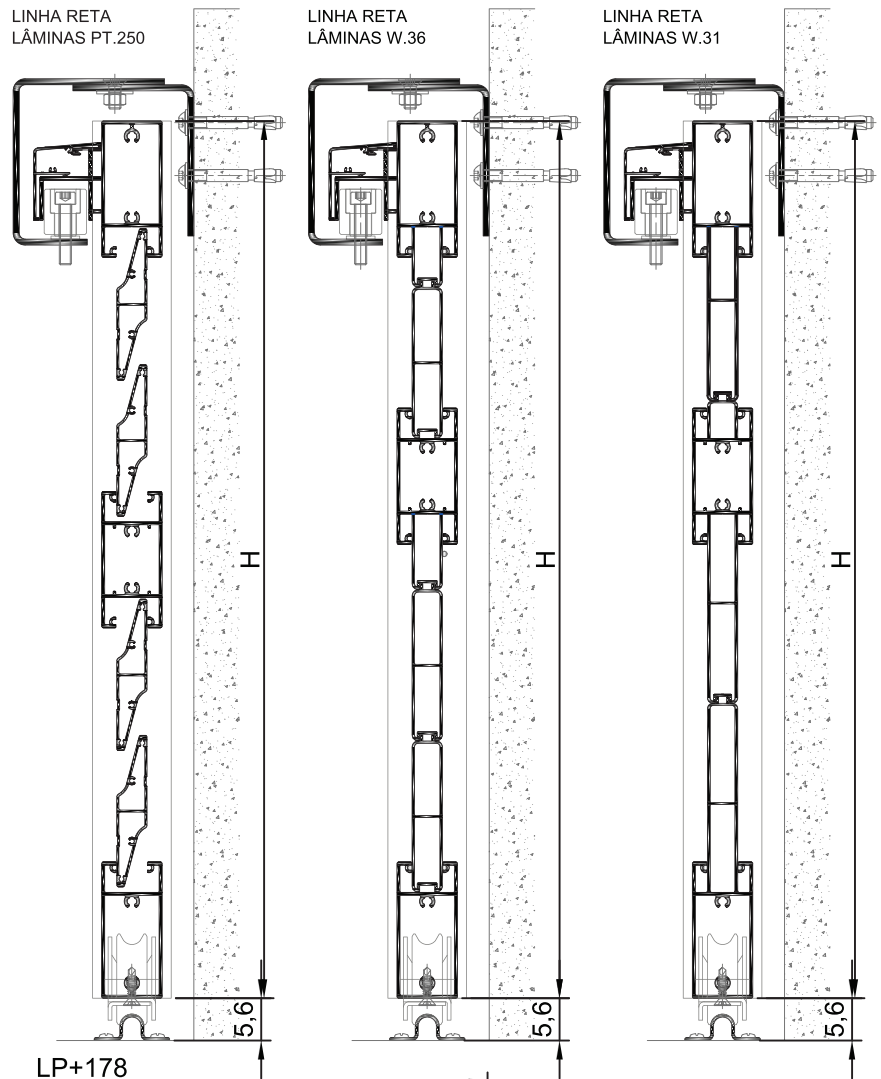

PORTÃO DE CORRER COM GUIA PT.265
LINHA REDONDA

PERFIS - PORTÃO CORRER COM LÂMINA PT.250					
REFª	DESIGNAÇÃO	CORTE HOR.	CORTE VERT.	QUANT	CORTE
PT.241	MONTANTE	-	H	2	
PT.266	ARO FIXO BATENTE	-	H+28	1	
PT.267	TAMPA	-	H+28	2	
PT.251	TAMPA	LP+178	H	1+4	
PT.242	TRAVESSA INF/SUP	LP+178	-	2	
PT.250	LÂMINA	LP-180	-	Variável	
PT.242	TRAV. CENTRAL (Op.)	LP-44	-	1	
PT.265	GUIA SUP CORRER	LP+107	-	1	
PT.264	GUIA SUP CORRER	LP+107	-	1	

PERFIS - PORTÃO CORRER COM LÂMINA W.31 ou W.36					
REFª	DESIGNAÇÃO	CORTE HOR.	CORTE VERT.	QUANT	CORTE
PT.241	MONTANTE	-	H	2	
PT.266	ARO FIXO BATENTE	-	H+28	1	
PT.267	TAMPA	-	H+28	2	
PT.251	TAMPA	LP+178	H	1+2	
PT.242	TRAVESSA INF/SUP	LP+178	-	2	
W.31 ou W.36	LÂMINA	LP-140	-	Variável	
PT.242	TRAV. CENTRAL (Op.)	LP-44	-	1	
PT.265	GUIA SUP CORRER	LP+107	-	1	
PT.264	GUIA SUP CORRER	LP+107	-	1	

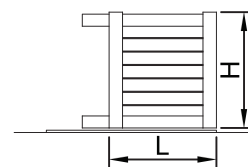

ACESSÓRIOS		
CÓDIGO	DESIGNAÇÃO	QUANTIDADE
200747	PUXADOR DUPLO 874.31	1*
227301	QUADRA AÇO 8mm	1*
201614	FECHADURA PRUMO 11552	1*
280243	TESTA PARA FECHADURA E06121101	1*
230006	SEGREGO 30/30 CHAV NIQUELADO	1*
207280	ROLAMENTO PA Nº.3 INOX	2*
223053	KIT GUIAS DE CORRER INOX	1*
214029	BATENTE PA Nº.1 INOX	1*
210036	TOPO PARA PT.241	4
210052	TOPO PARA PT.242	2
210038	TOPO PARA PT.266	1
210037	TOPO PARA PT.265	2
232009	UNIÃO PARA GUIA INOX 20052	1**
207136	GUIA INOX PA 20049 (3m)	Lx2
290270	PAR 6,3x50 Inox A2 + ANILHA (Para travessas)	Variável
290267	PAR. M8x60 Inox C/AN+BUC. MET.(Para guias)	3
290111	PAR. CQ 4,2x13 INOX (Para Lâmina PT.250)	Variável
290112	PAR. M4x12 Inox (Para Tampas PT)	Variável
290113	PARAFUSO CX 6,3x32 INOX	4

* Opcional ** Para guias superiores a 3,00m

VEDANTES			
CÓDIGO	DESIGNAÇÃO	QUANTIDADE	
208008	VD 2051	2H	
208564	VEDANTE PELÚCIA 4,8X7	2H	
208221	VD 1033	COM PA 50	8H
		COM KW 82 ou 92	6L+8H

LINHA REDONDA
LÂMINAS PT.250

LINHA REDONDA
LÂMINAS W.36

LINHA REDONDA
LÂMINAS W.31

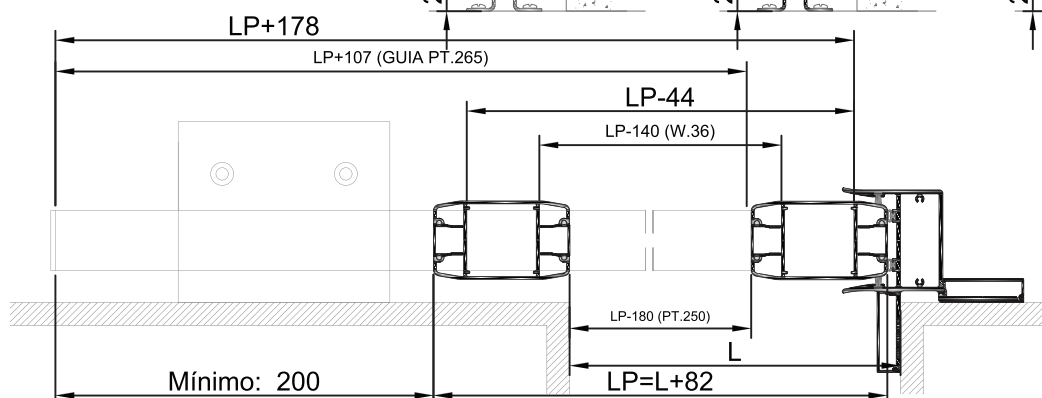
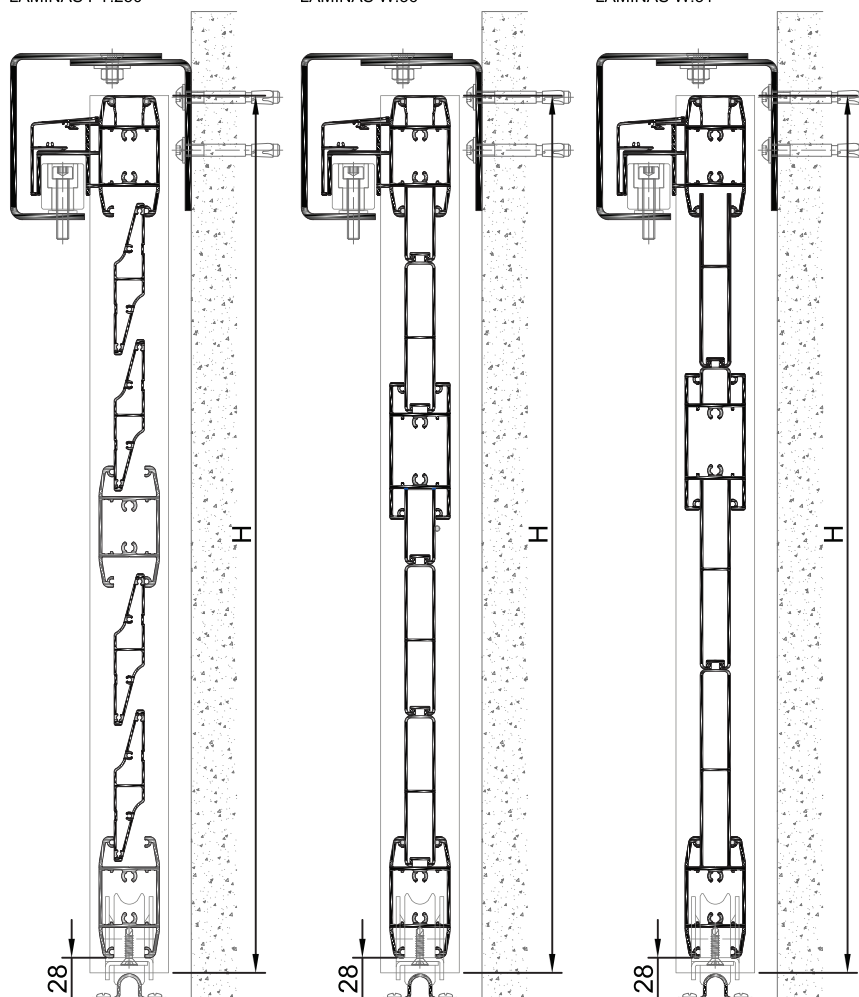



NORTALU[®]

📍 **Rua Dr. José Bragança Tavares, 78 Fr. A
4580-593 Paredes(Mouriz)**

☎ **255 781 548/49**

☎ **92 705 80 65**

✉ **nortalu@nortalu.com**



📍 **Trial Aluminium System - Zona Industrial Achada Grande Trás**

☎ **(+238) 2631056**

☎ **(+238) 263 1058**

☎ **(+238) 9189881**

✉ **geral.trial@nortalu.com**