

SÉRIE AQ

SISTEMA BATENTE CÂMARA EUROPEIA

Sistema de batente com vedação central e câmara de dimensões europeias, de acordo com o normativo de uniformização, permitem a utilização de uma vasta gama de acessórios de alta qualidade. A série é constituída por perfis de formas retas, curvas ou então na combinação entre o rigor técnico e a harmonia estética através do modelo tradição/decorativo. Tratando-se de uma série bastante versátil.

Resultados do Ensaio do Tipo Inicial:

Tipo Ensaio	Resultados
Permeabilidade ao Ar	4
Estanquidade à Água	8A
Resistência à Pressão do Vento	C5
Durabilidade Mecânica	-
Coefficiente de Transmissão Térmica	4,2
Desempenho Acústico	34

Janela com perfis alumínio do Sistema AQ composta por duas folhas móveis de batente. Dimensão da Janela: 1500*1200 mm

Soluções Construtivas:

- Fixos;
- Janelas e Portas;
- Basculantes;
- Projetantes;
- Vai e Vem.

Capacidade de Vidro:

- Vidro Simples: 4 a 12mm
- Vidro Duplo: 12 a 38mm

Vedantes:

- Material em EPDM ou PVC em conformidade com a norma aplicável.

Acessórios:

- Materiais em alumínio, zamac, aço inox e nylon em conformidade com a norma aplicável.



AQ.01 *Aro Fixo*

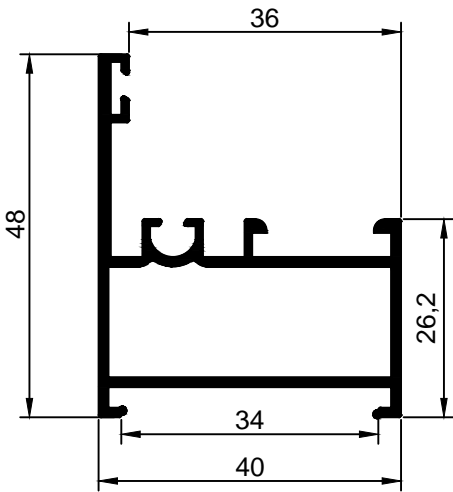

AQ.02 *Aro Fixo*

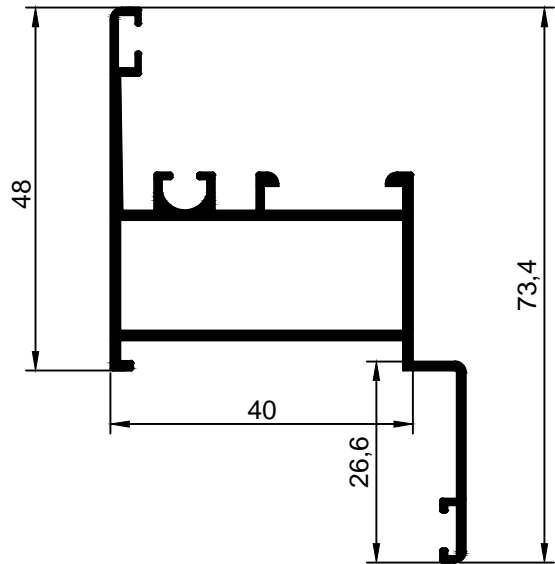

AQ.04 *Aro Fixo*

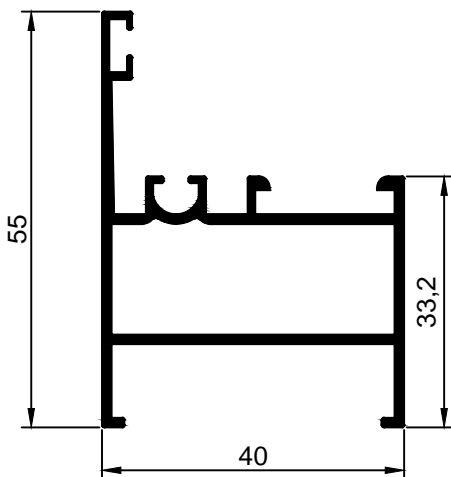

AQ.03 *Aro Fixo*

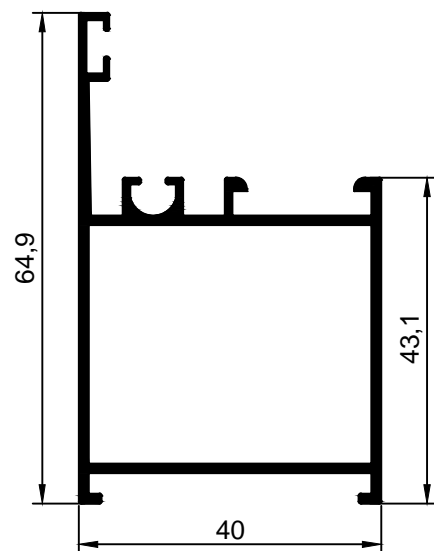

AQ.05 *Aro Fixo*

AQ.06 *Aro Fixo*

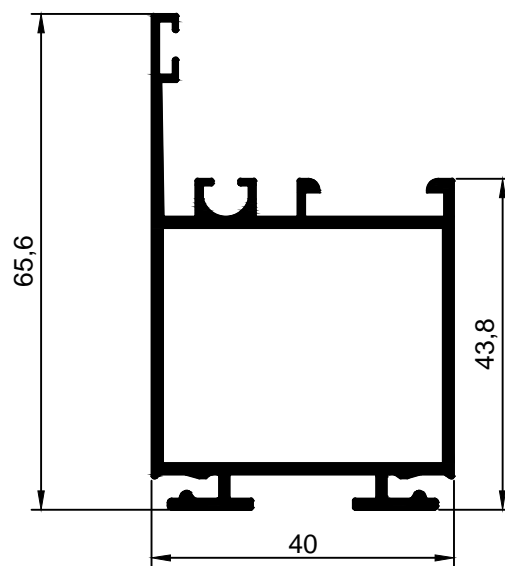
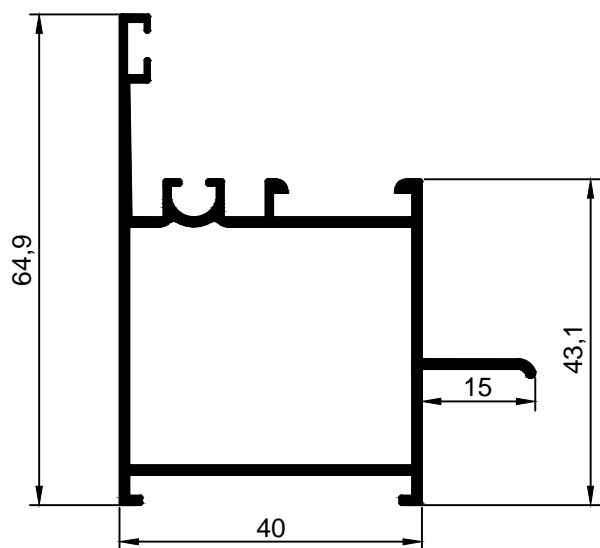

AQ.08 *Aro Fixo Tradição*

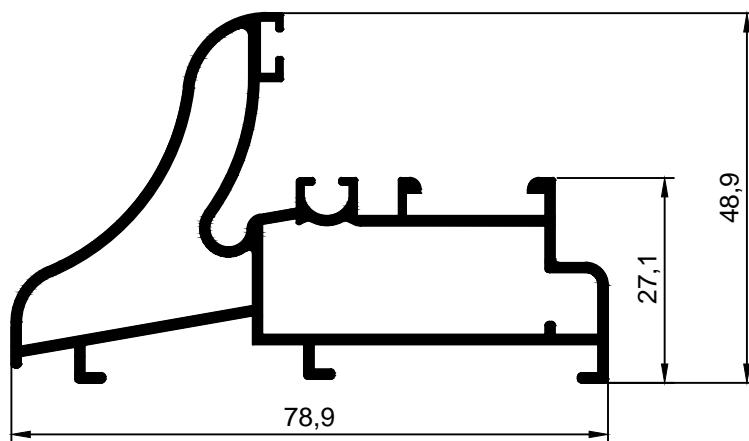

AQ.09 *Aro Fixo Tradição*

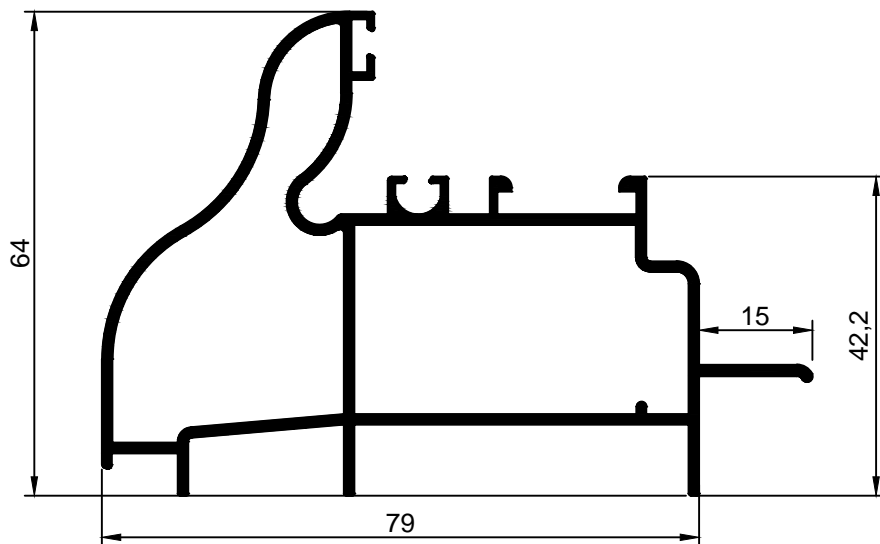

AQ.10 *Aro Fixo Tradição*

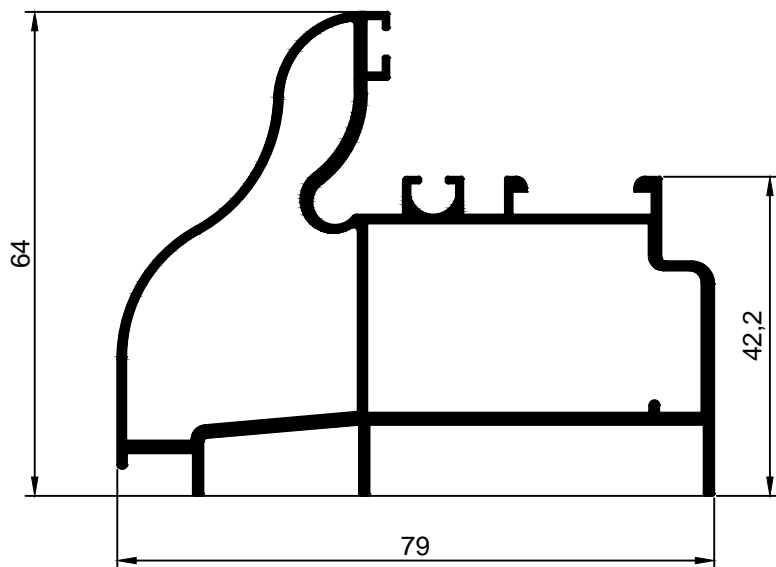

AQ.12 Travessa

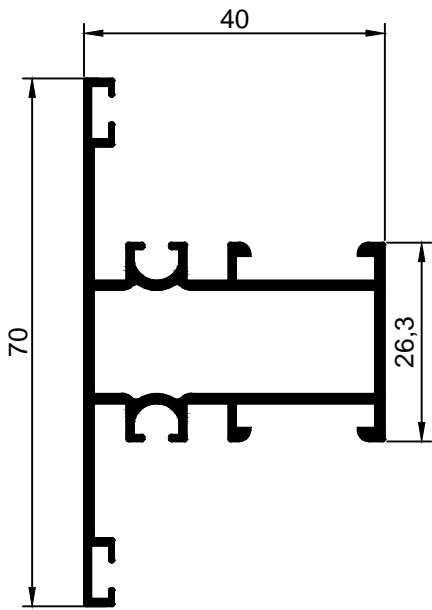

AQ.14 Travessa

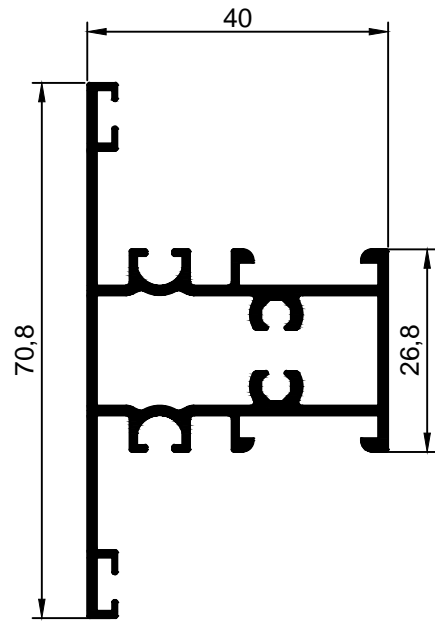

AQ.11 Travessa

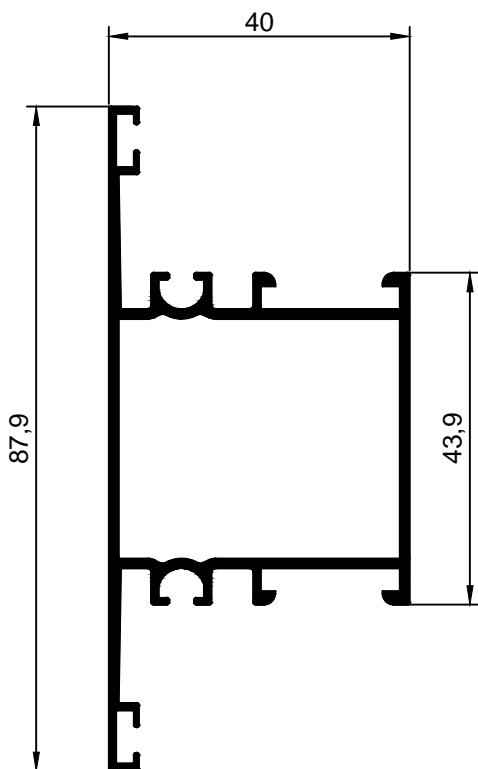

AQ.13 Travessa

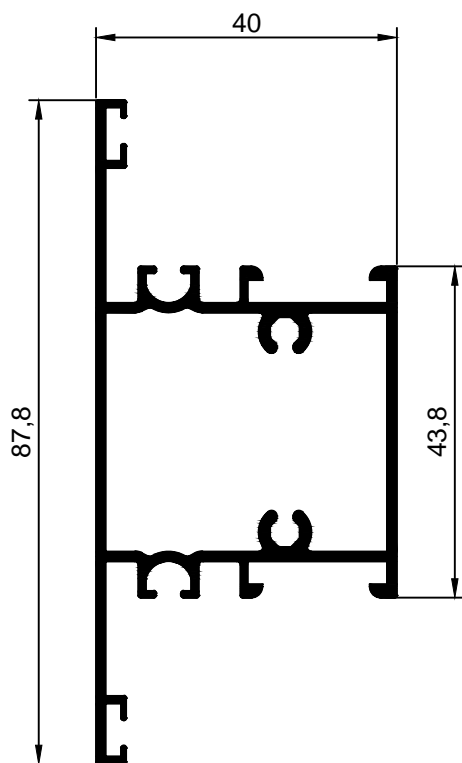

AQ.15 *Travessa Inversora*

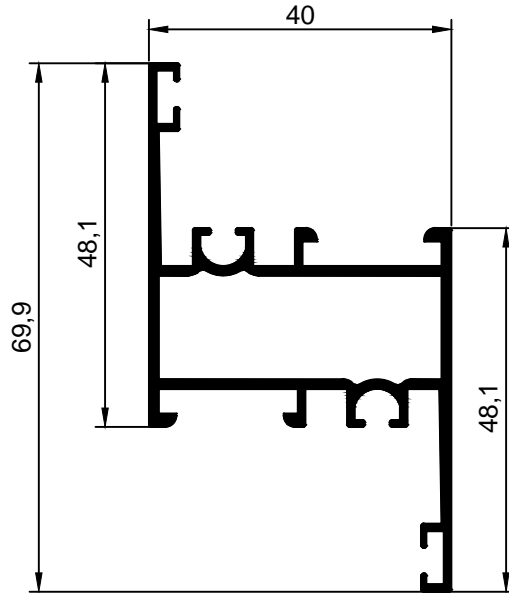

AQ.16 *Travessa Inversora*

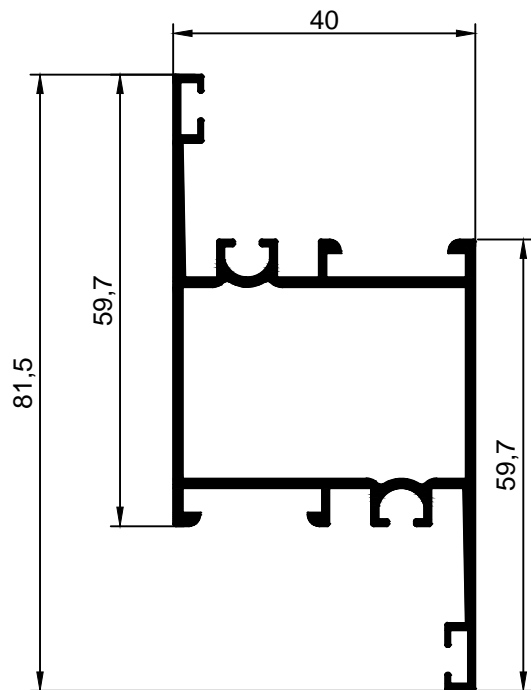

AQ.17 *Montante*

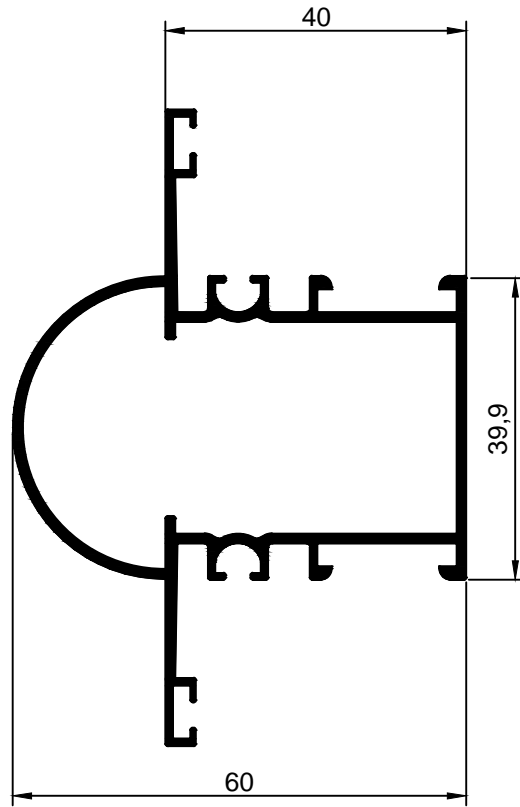

AQ.18 *Montante*

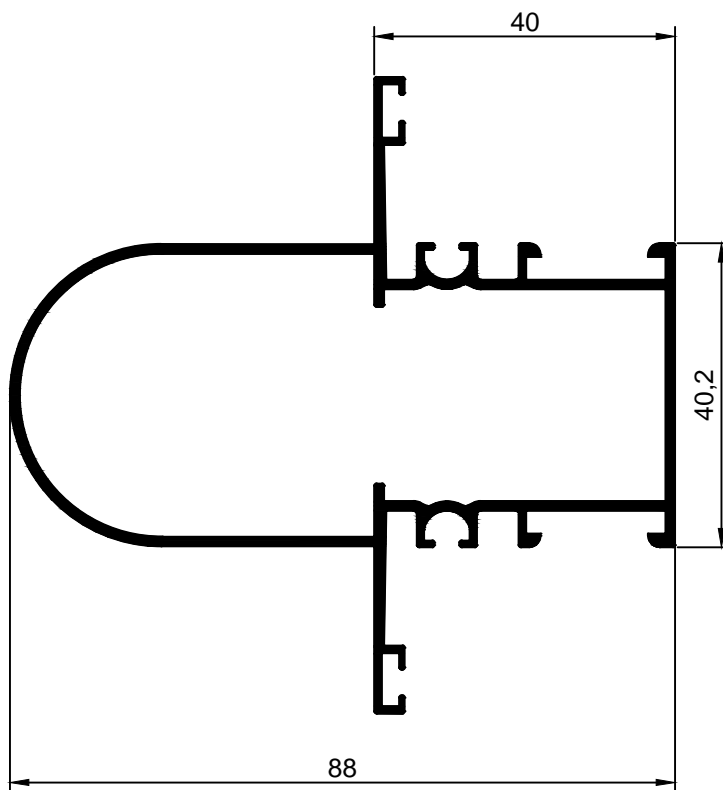

AQ.19 *Montante*

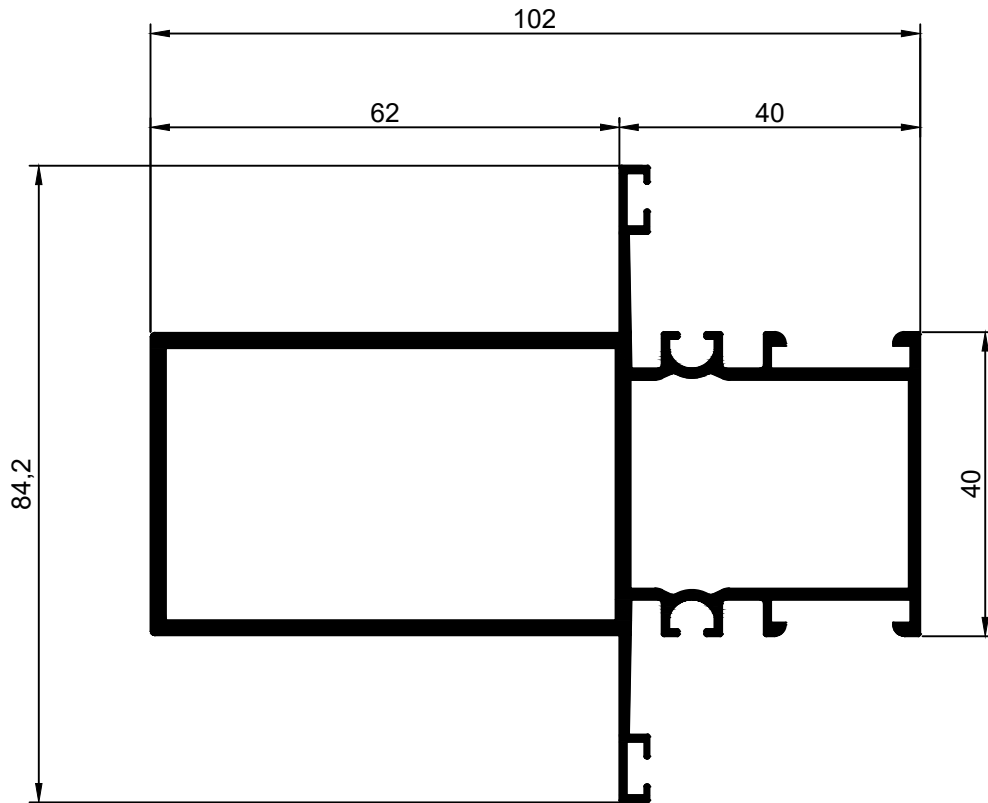

AQ.71 *Inversor*

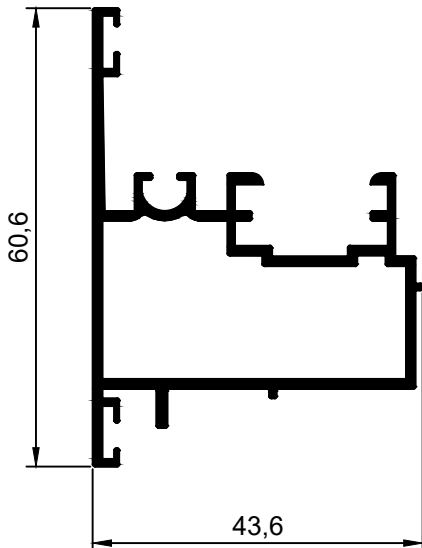

AQ.72 *Inversor*

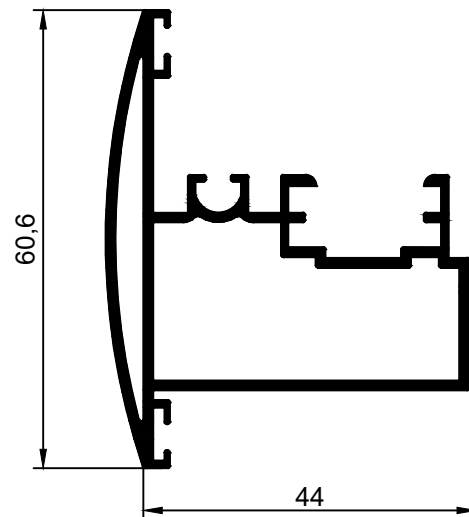

AQ.22 Aro Móvel

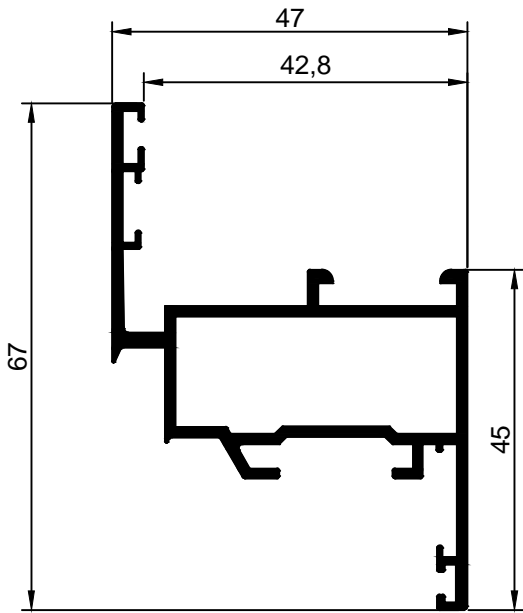

AQ.21 Aro Móvel

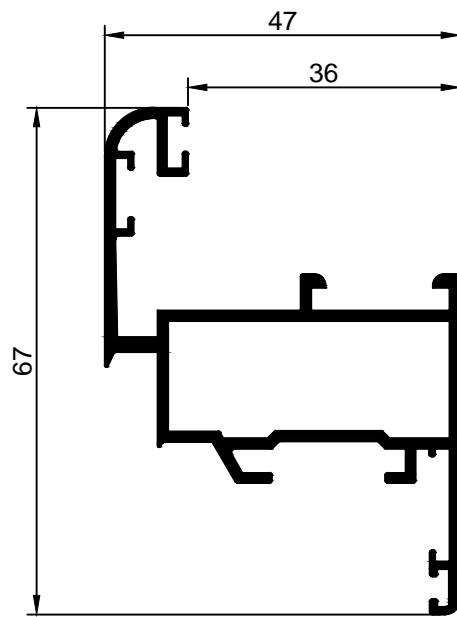

AQ.32 Aro móvel

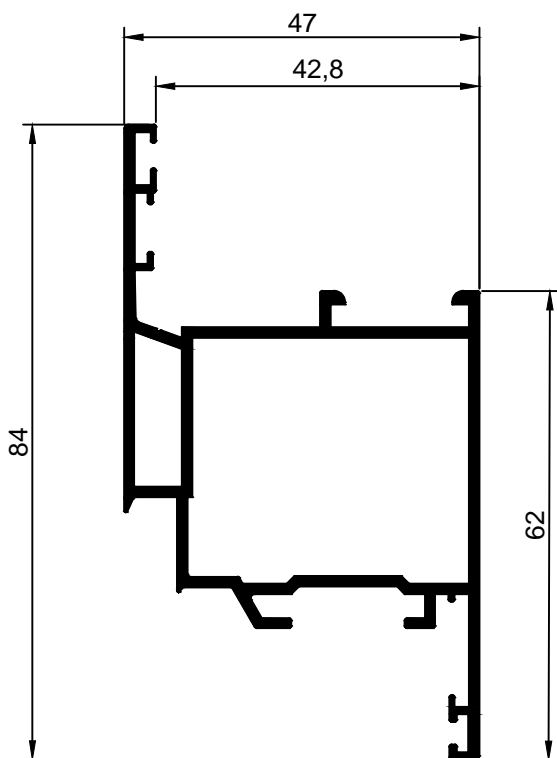

AQ.31 Aro móvel

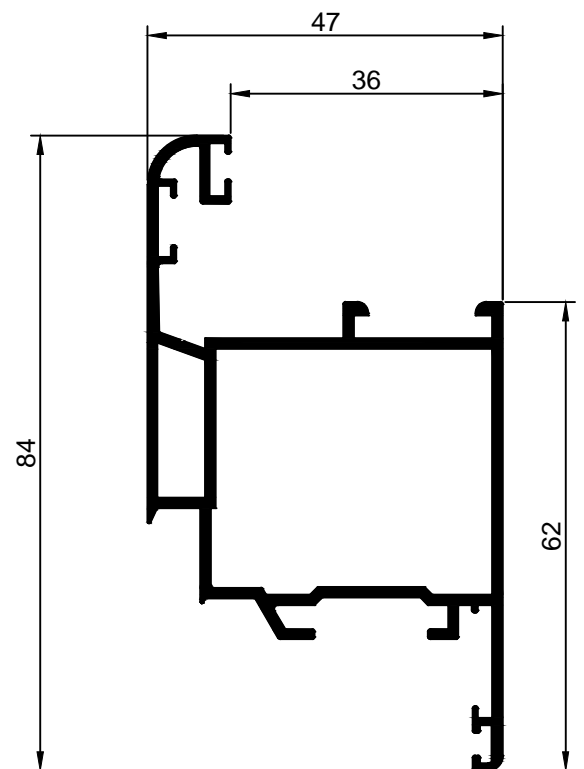

AQ.34 Aro Móvel

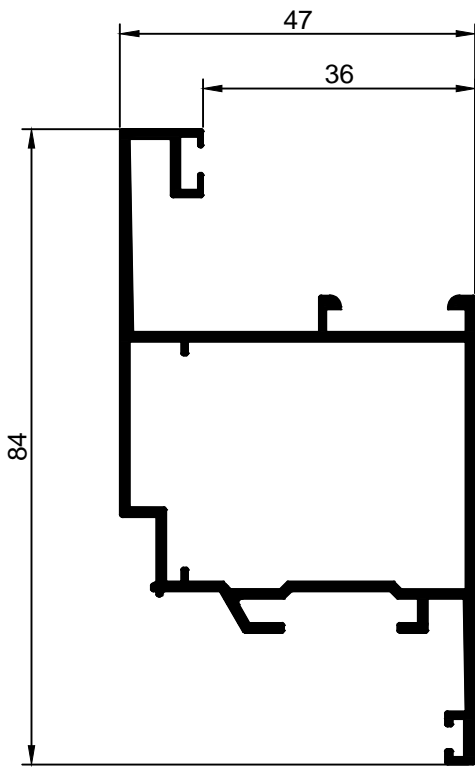

AQ.35 Aro Móvel

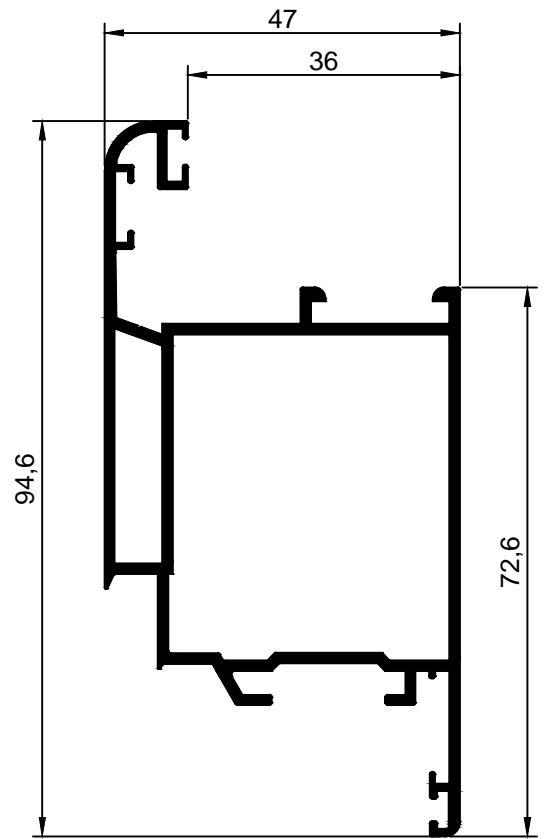

AQ.37 Aro Móvel Abt. Exterior

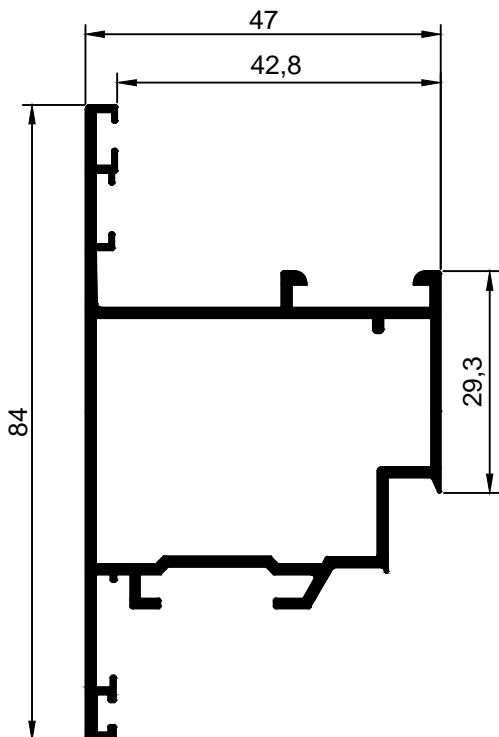

AQ.33 Aro Móvel Abt. Exterior

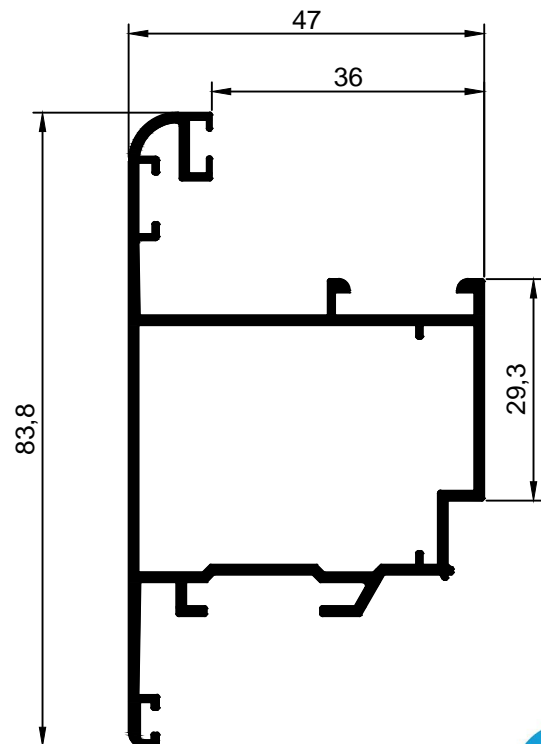

AQ.28 Aro Móvel

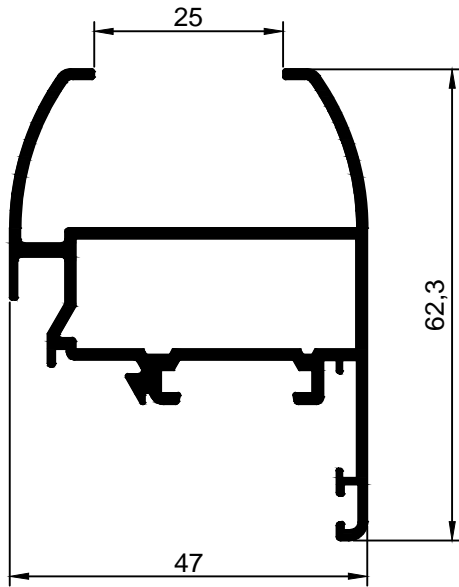

AQ.26 Aro Móvel

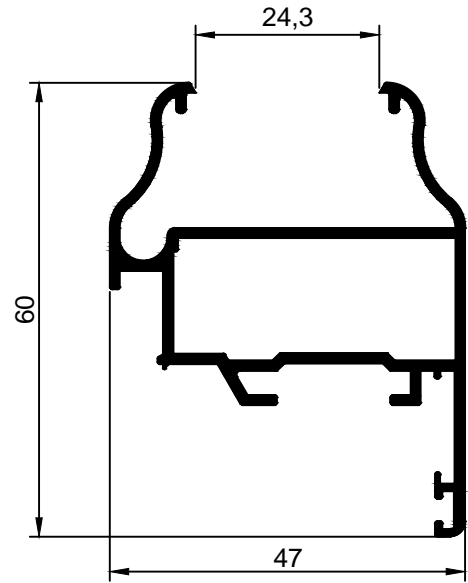

AQ.38 Aro Móvel

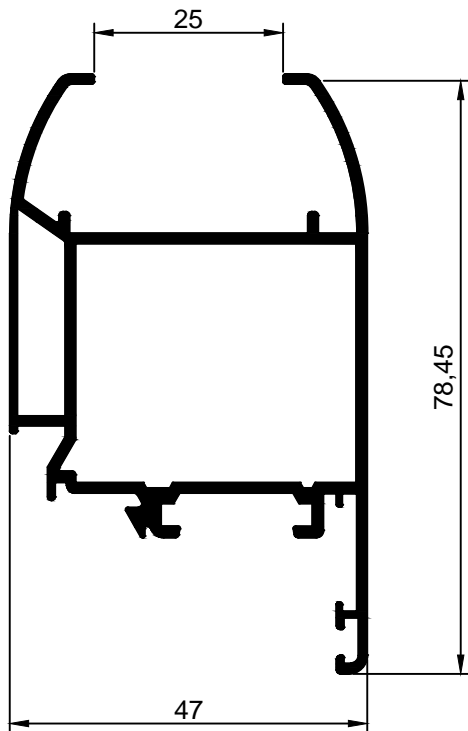

AQ.36 Aro Móvel

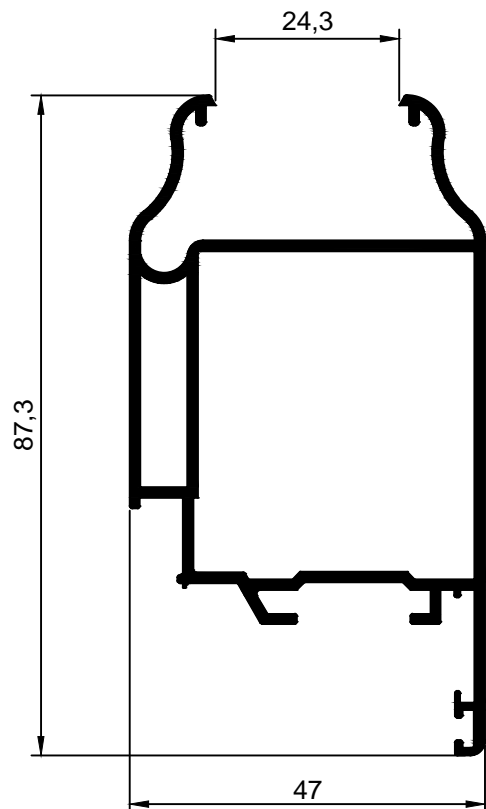

AQ.41 *Travessa Central*

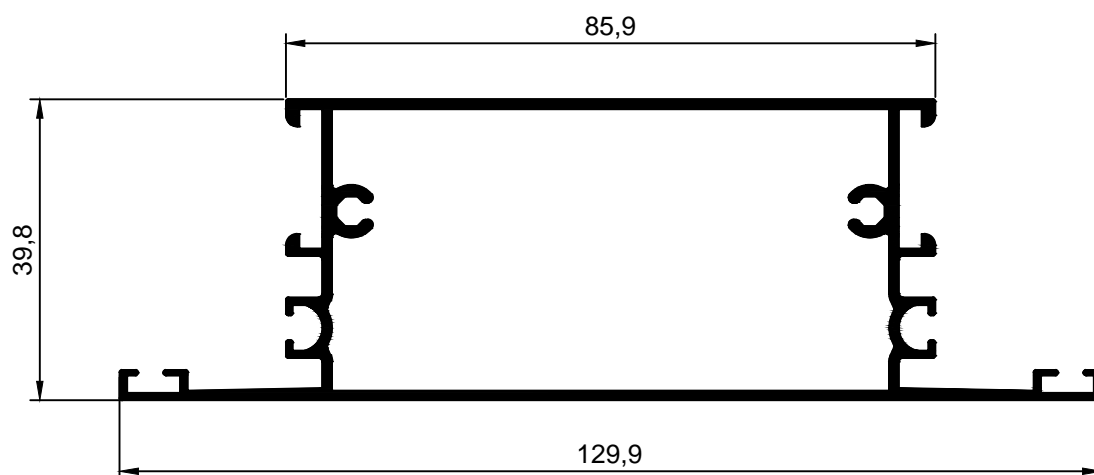

AQ.42 *Travessa Inferior*

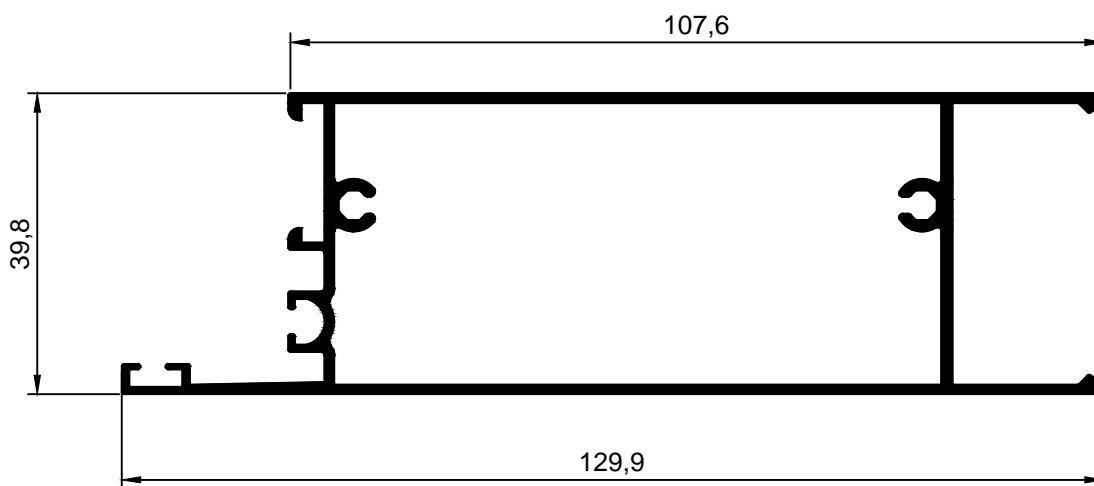

AQ.43 *Travessa Central*

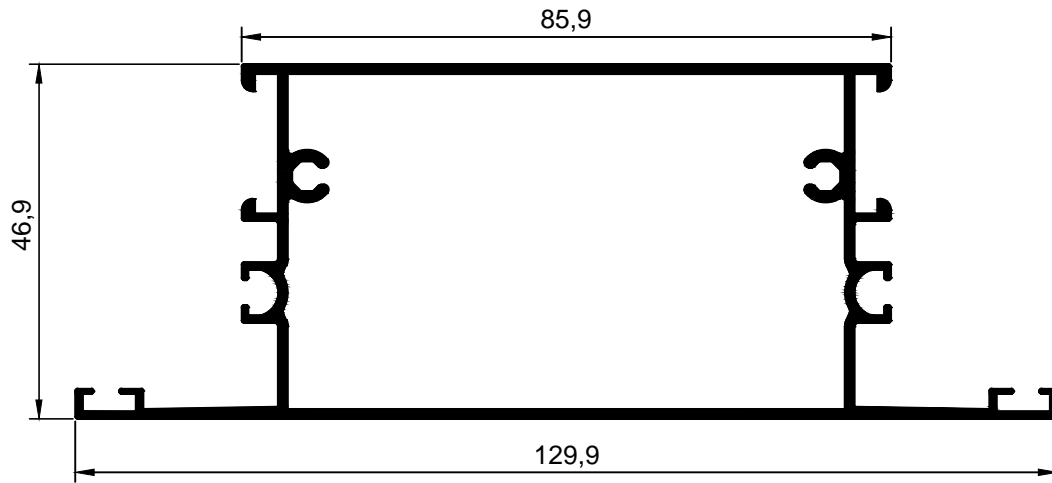

AQ.44 *Travessa Inferior*

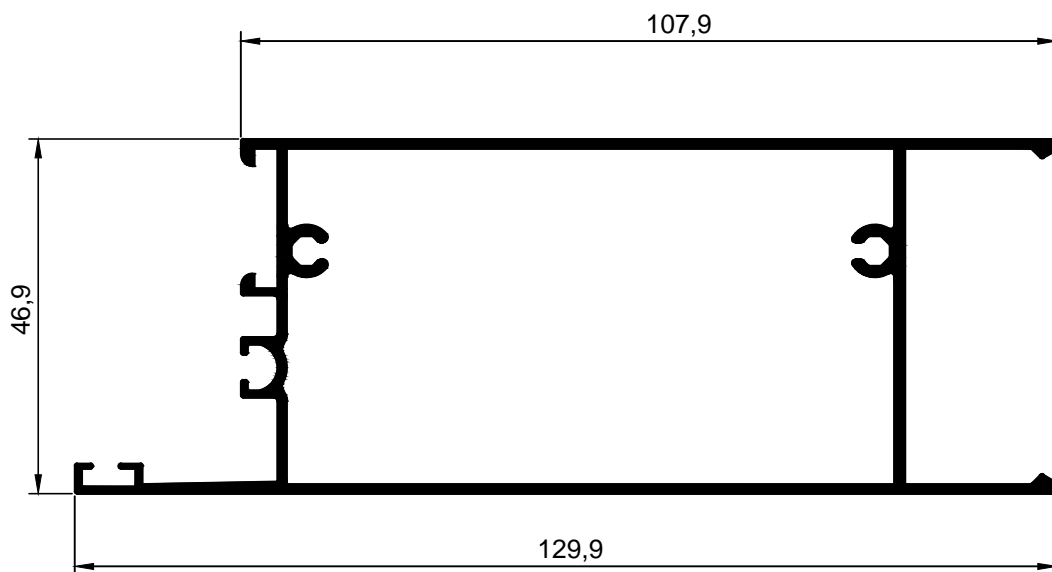

AQ.47 *Travessa Inferior*

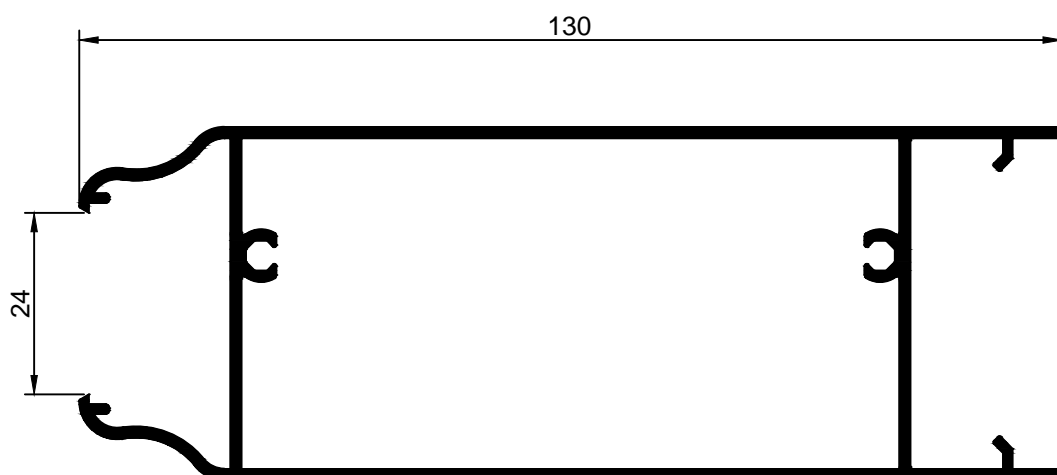

AQ.46 *Travessa Central*

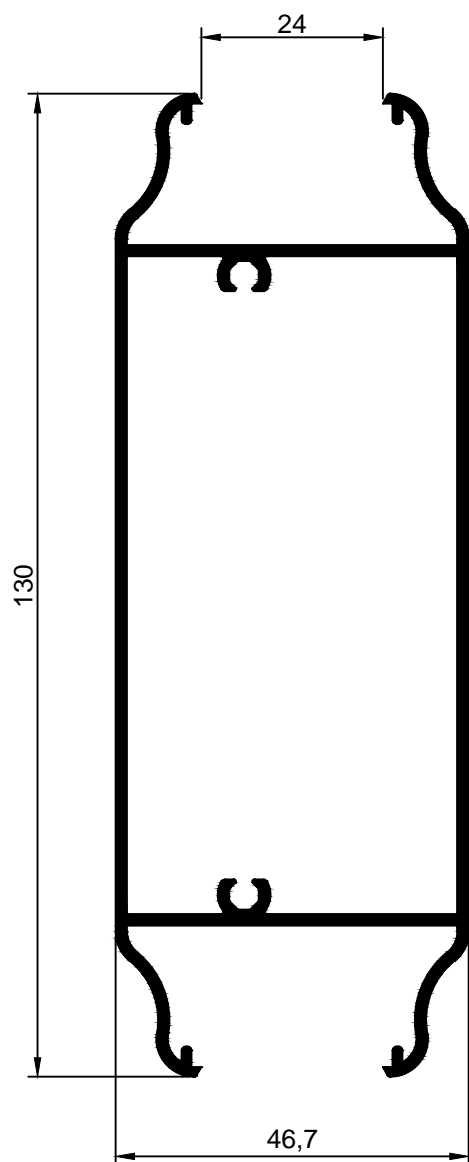

AQ.45 *Travessa Central Pequena*

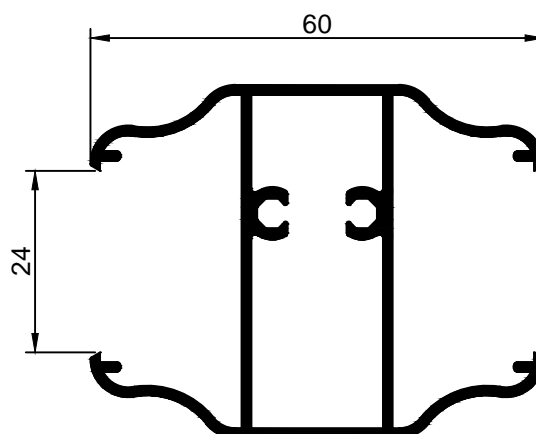

AQ.48 *Travessa Central*



AQ.49 *Travessa Inferior*

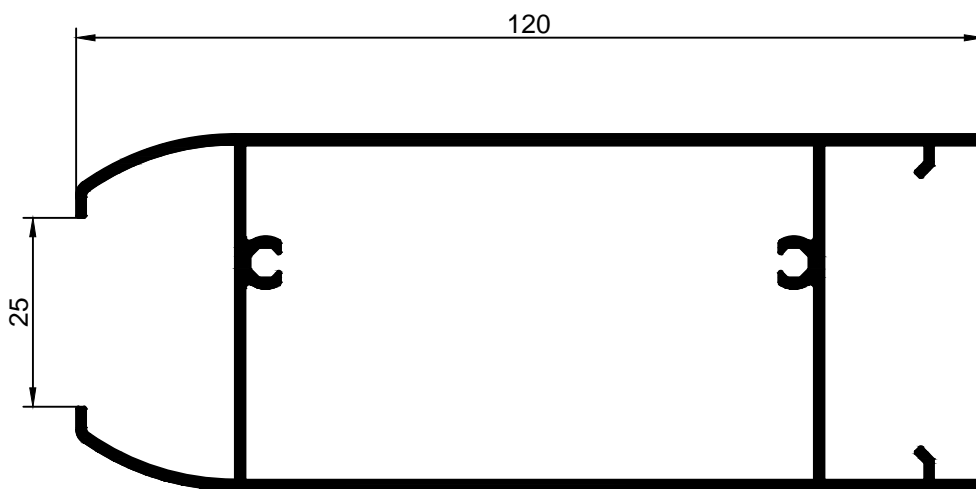

AQ.84 *Soleira Condensação*

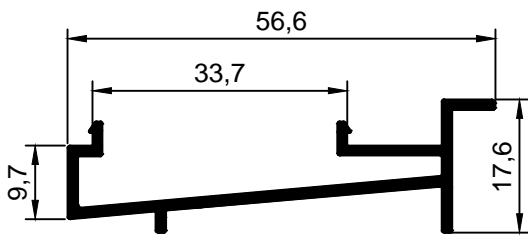

AN.81 *Soleira Condensação*

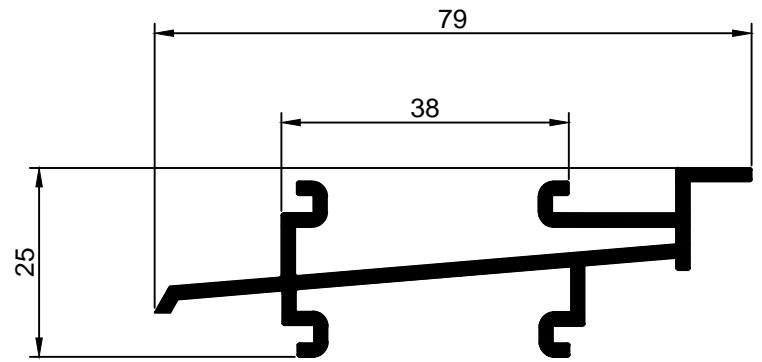

AQ.83 *Soleira Condensação*

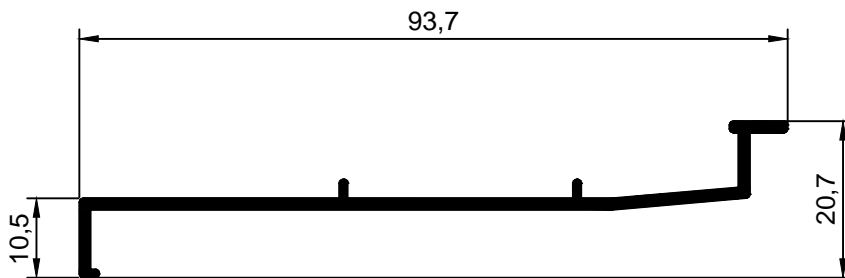

AQ.82 *Soleira Condensação*

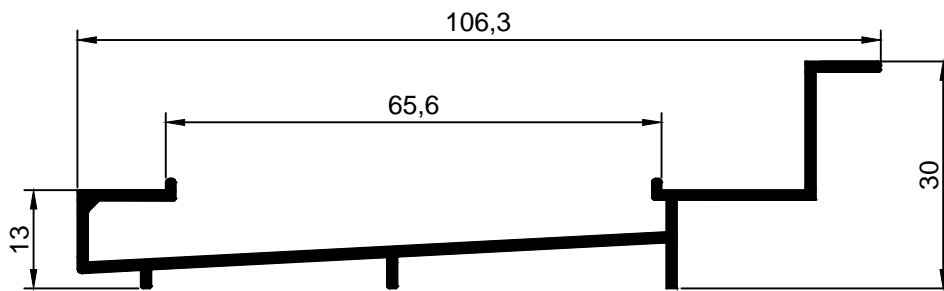

AQ.89 *Soleira Condensação*

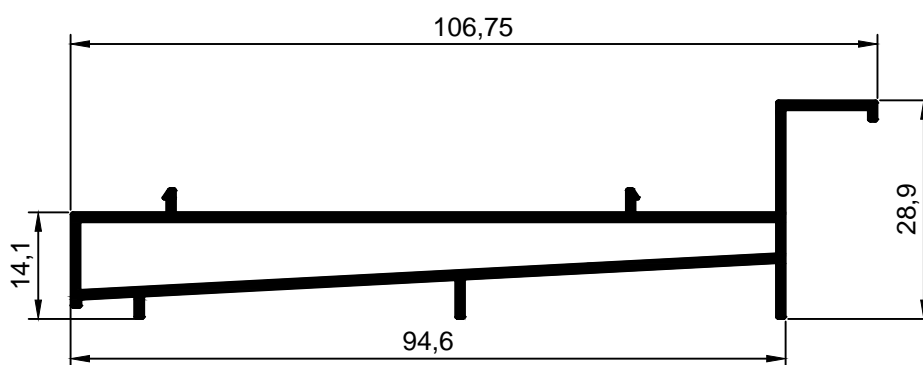

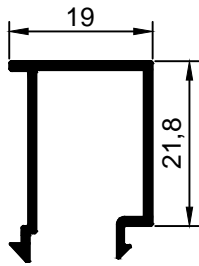

AQ.55 *Bite*

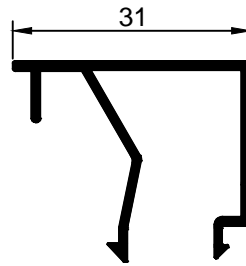

AQ.59 *Bite*

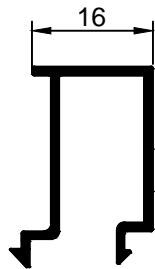

AQ.54 *Bite*

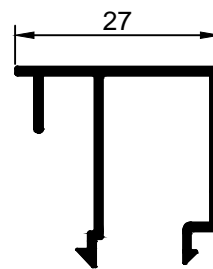

AQ.58 *Bite*

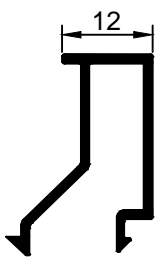

AQ.53 *Bite*

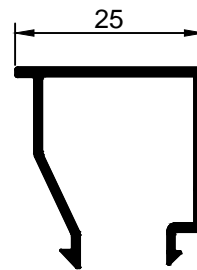

AQ.57 *Bite*

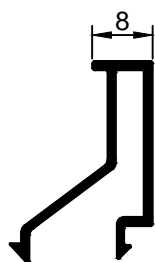

AQ.52 *Bite*

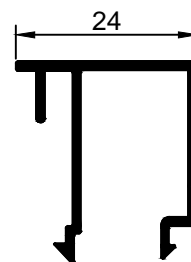

AQ.50 *Bite*

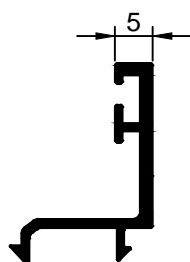

AQ.51 *Bite*

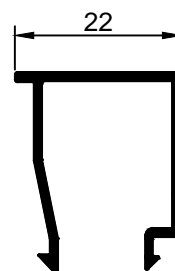

AQ.56 *Bite*

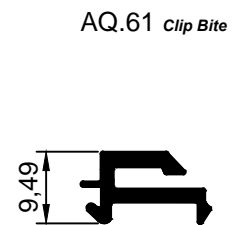
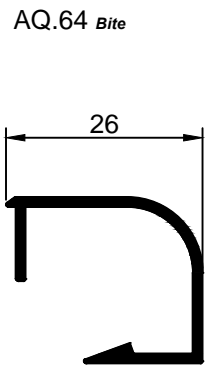
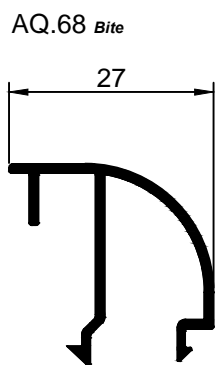
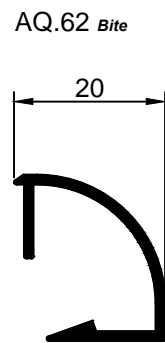
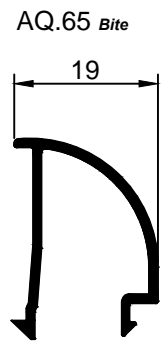
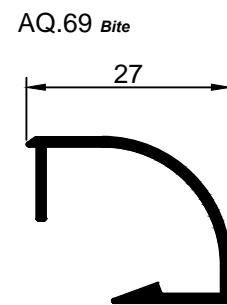
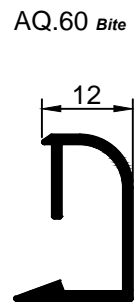
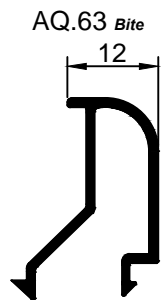

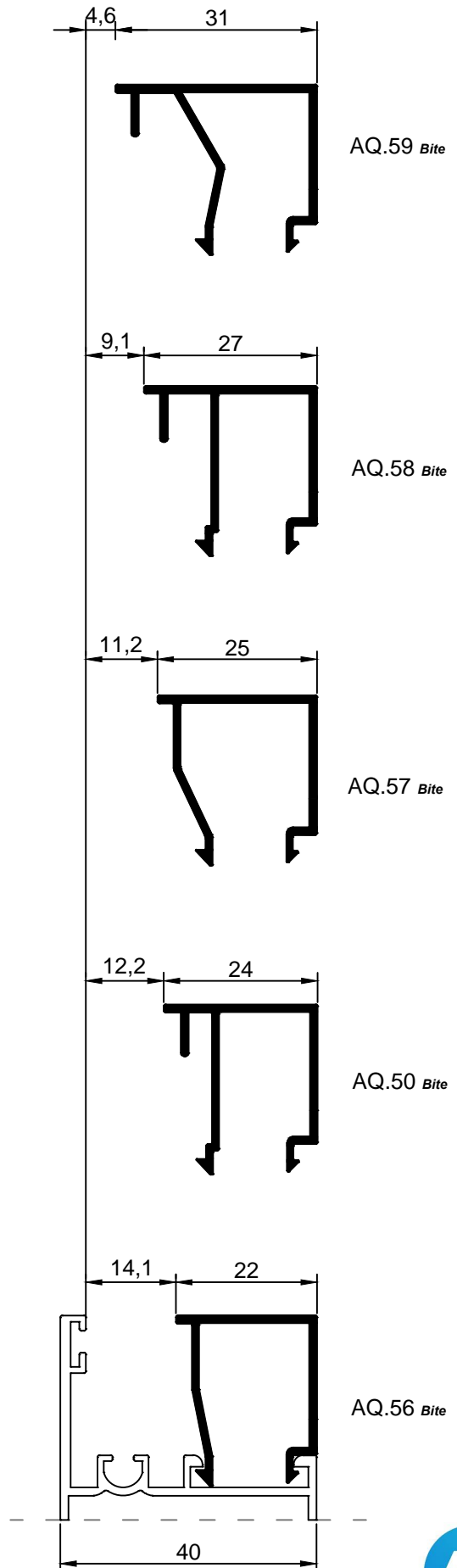
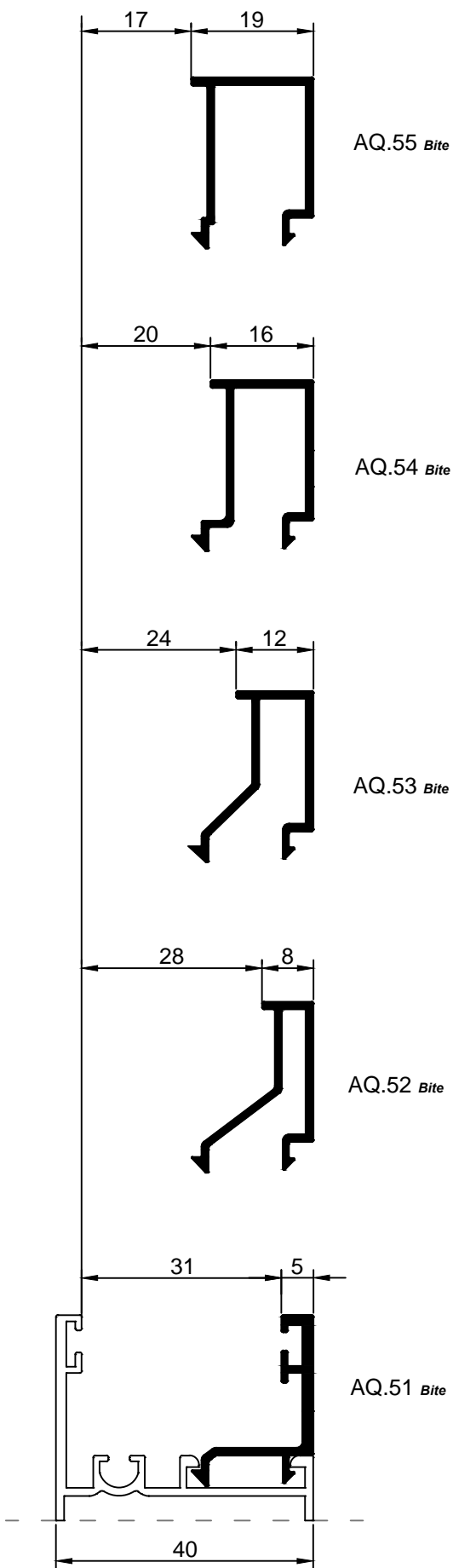

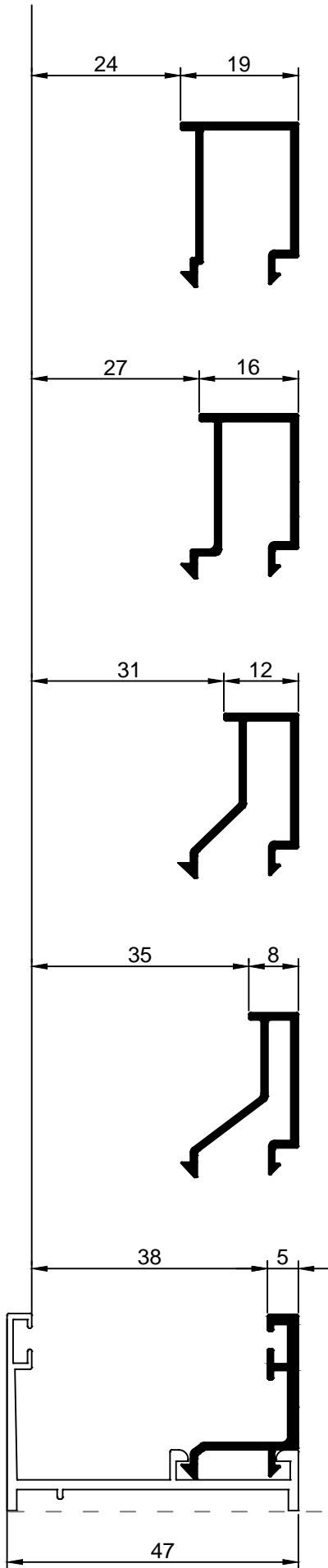

AQ.55 *Bite*

AQ.54 *Bite*

AQ.53 *Bite*

AQ.52 *Bite*

AQ.51 *Bite*

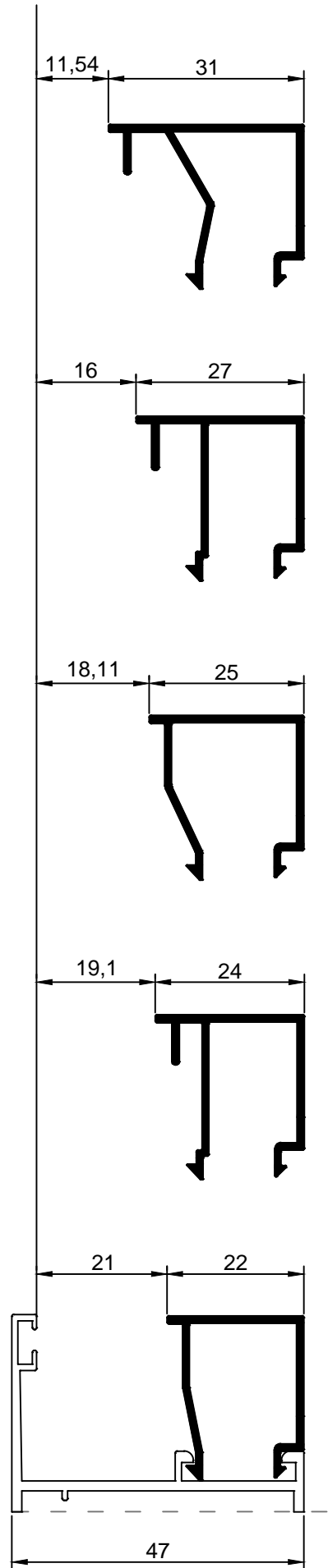

AQ.59 *Bite*

AQ.58 *Bite*

AQ.57 *Bite*

AQ.50 *Bite*

AQ.56 *Bite*

AQ.85 *Soleira Inferior Portas*

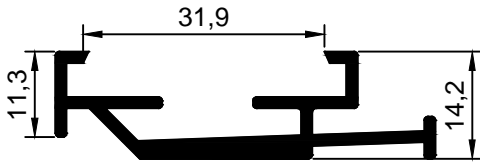

AQ.86 *Bite Vedação Inferior*

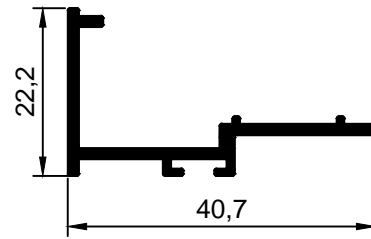

AQ.74 *Bite Vedação Inferior*

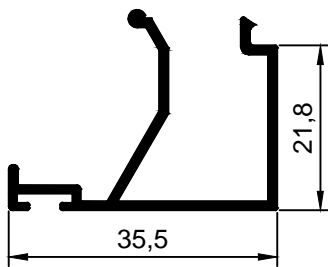

AQ.88 *Remate/Ligação*

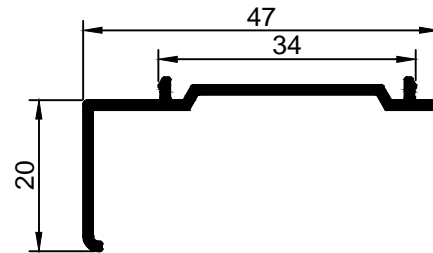

RQ.85 *Soleira Inferior Portas*

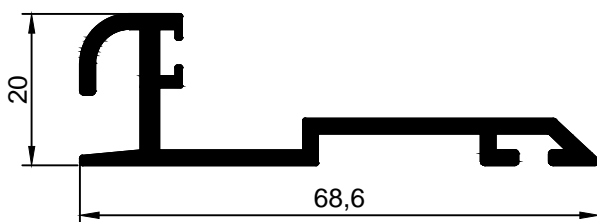

AQ.87 *Soleira Condensação*

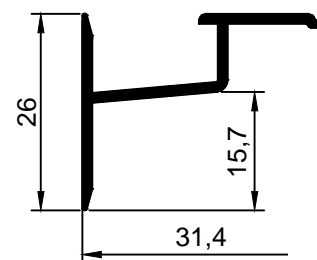

AQ.92 *Bite Redutor*

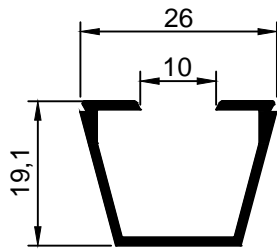

AQ.94 *Vareta Cremone*

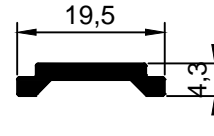

AQ.96 *Pingadeira*

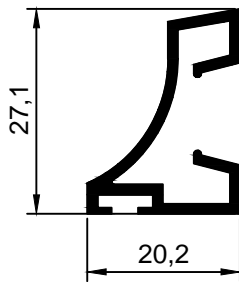

AQ.97 *Clip Pingadeira*

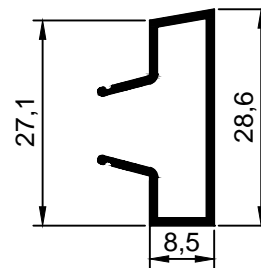

AQ.96A *Pingadeira*

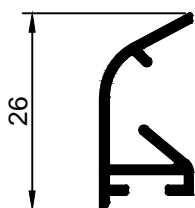

AQ.97A *Clip Pingadeira*

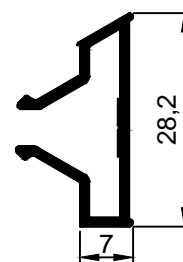

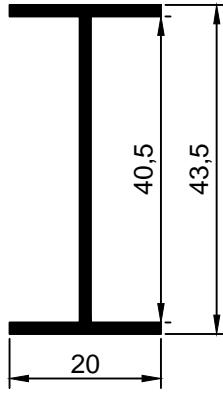

ST.84A *Perfil Ligação*

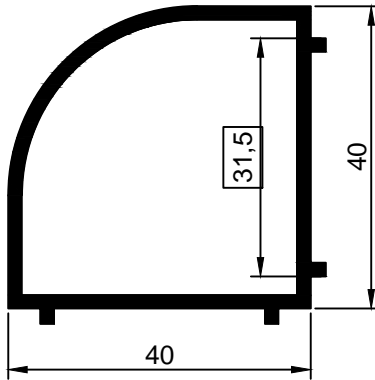

AN.72 *Perfil Ligação 90°*

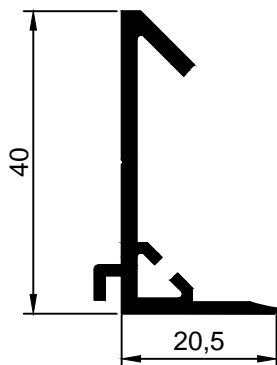

ST.82 *Perfil Ligação Angular*

RQ.108 *Remate*

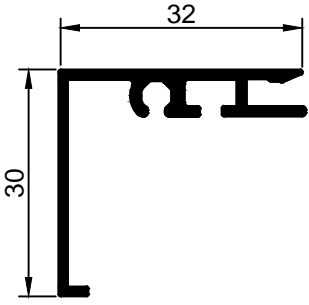

RQ.101 *Remate*

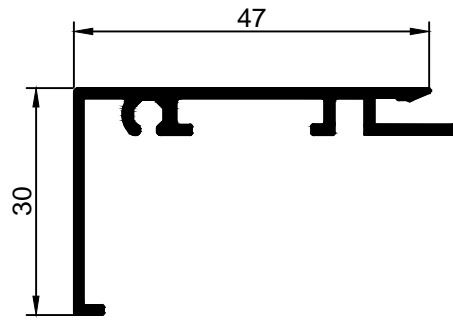

RQ.109 *Remate*

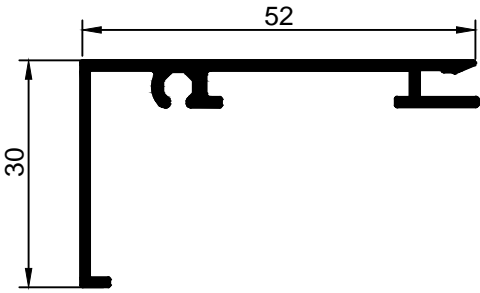

RQ.102 *Remate*

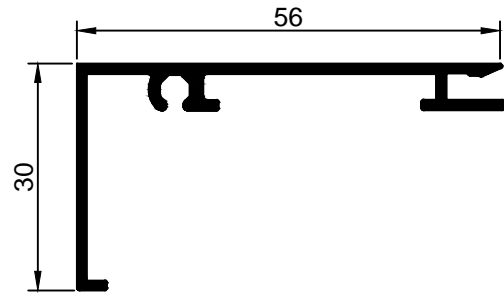

RQ.103 *Remate*

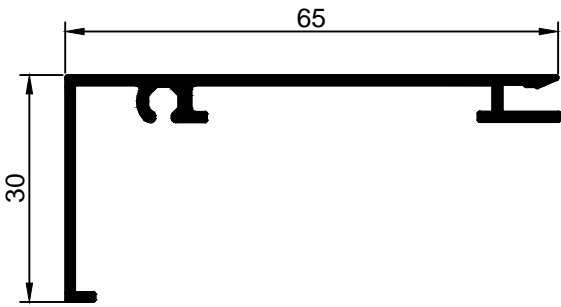

RQ.104 *Remate*

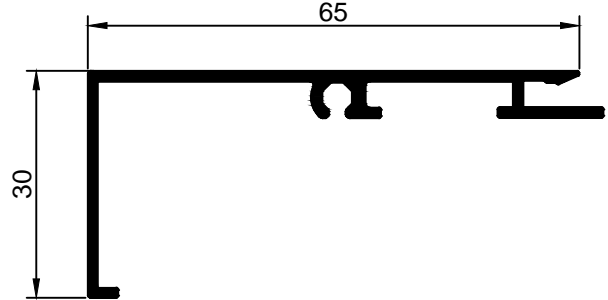

RQ.106 *Remate*

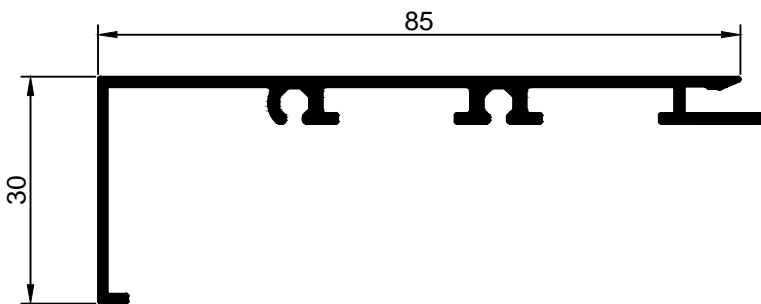

RQ.105 *Remate*

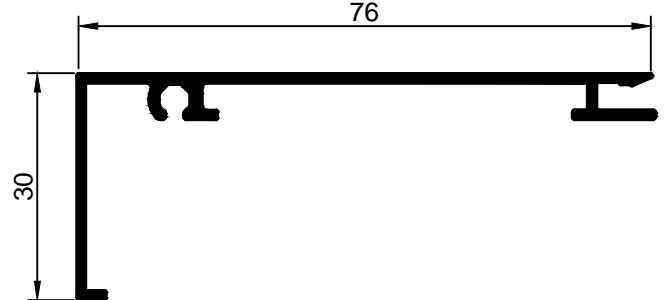

RQ.107 *Remate*

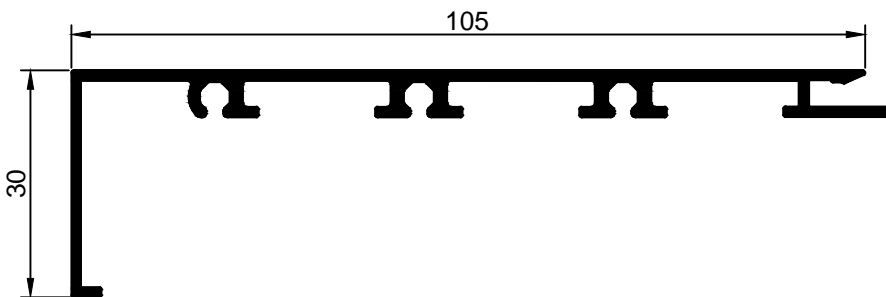

AQ.151 *Remate*

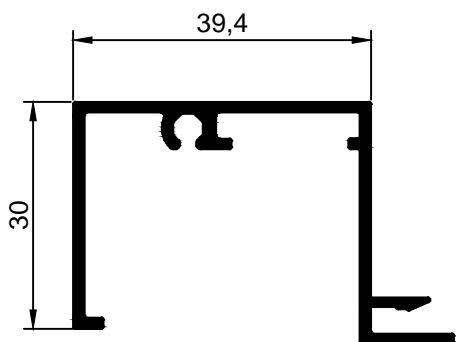

AQ.152 *Remate*

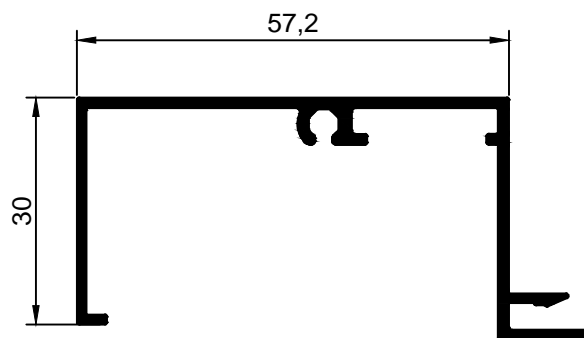

AQ.153 *Remate*

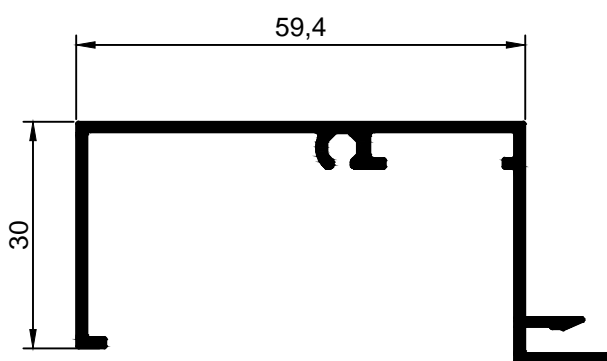

AQ.154 *Remate*

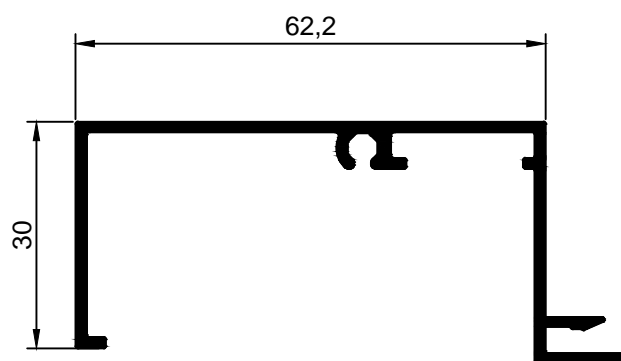

AQ.155 *Remate*

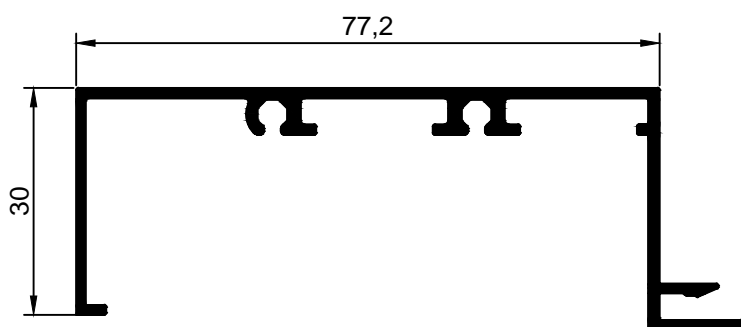

AQ.156 *Remate*

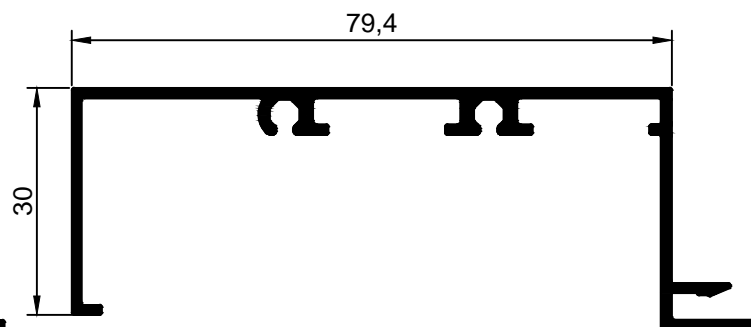

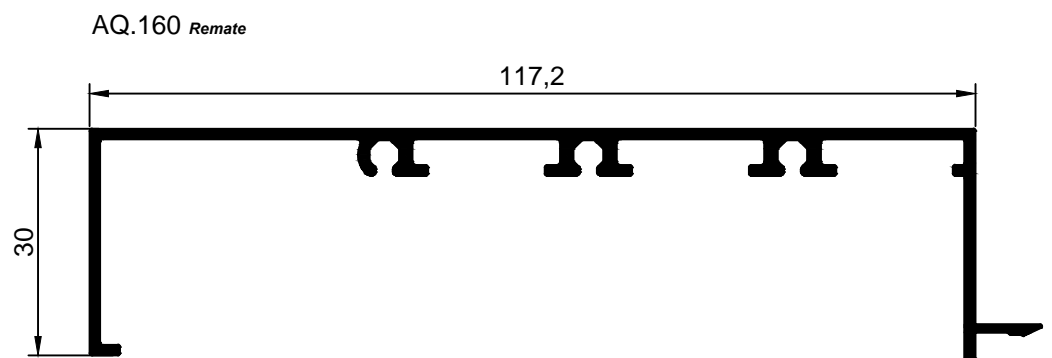
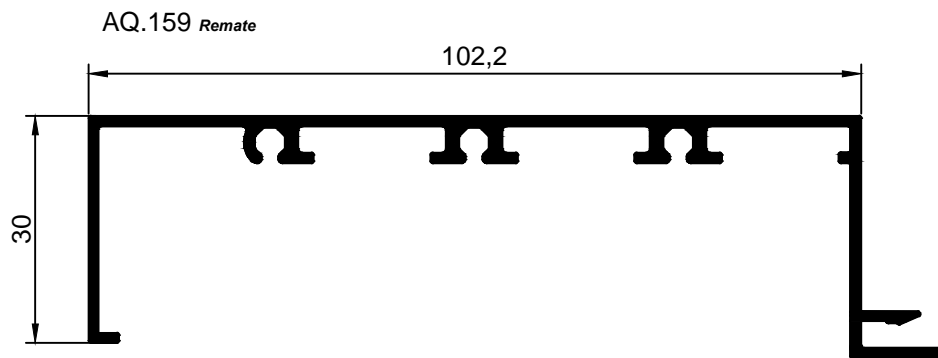
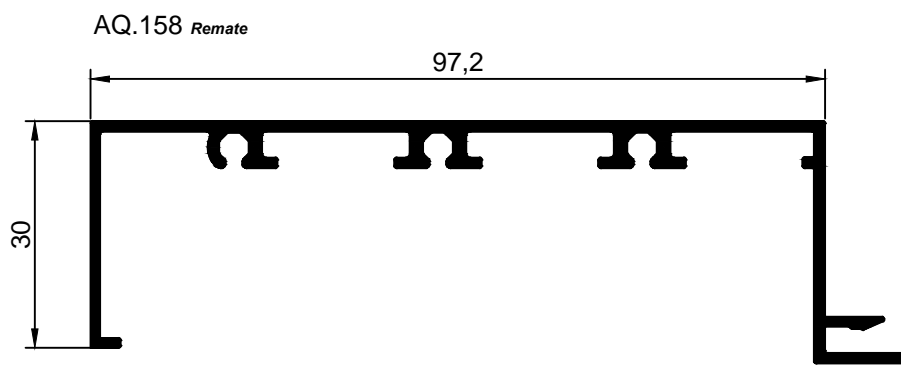
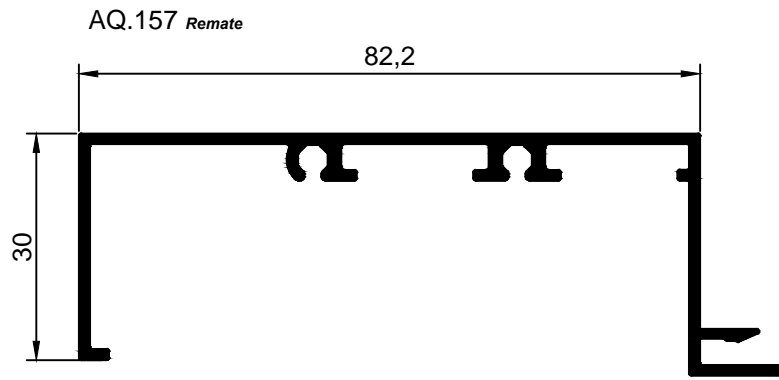

AQ.121 *Remate*

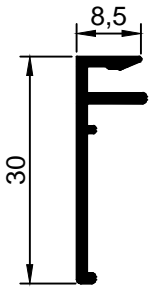

AQ.126 *Remate*

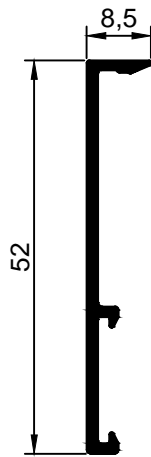

AQ.127 *Remate*

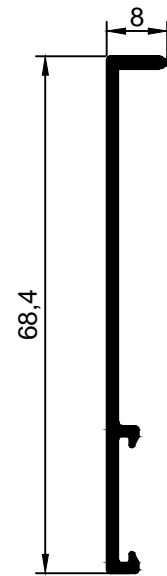

AQ.123 *Remate*

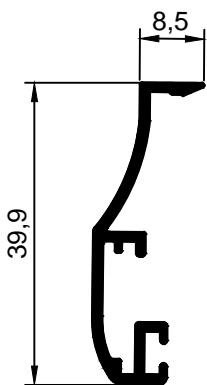

AQ.124 *Remate*

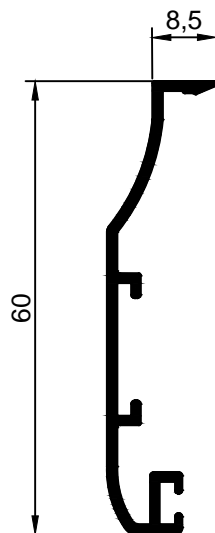

AQ.125 *Remate*

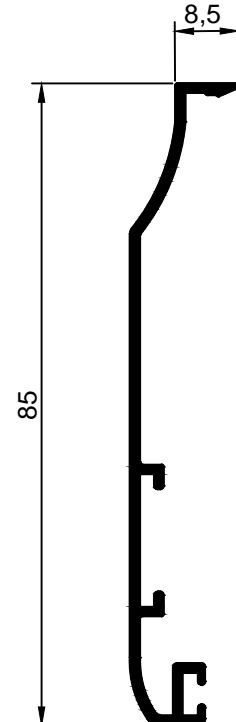

AQ.109 Remate

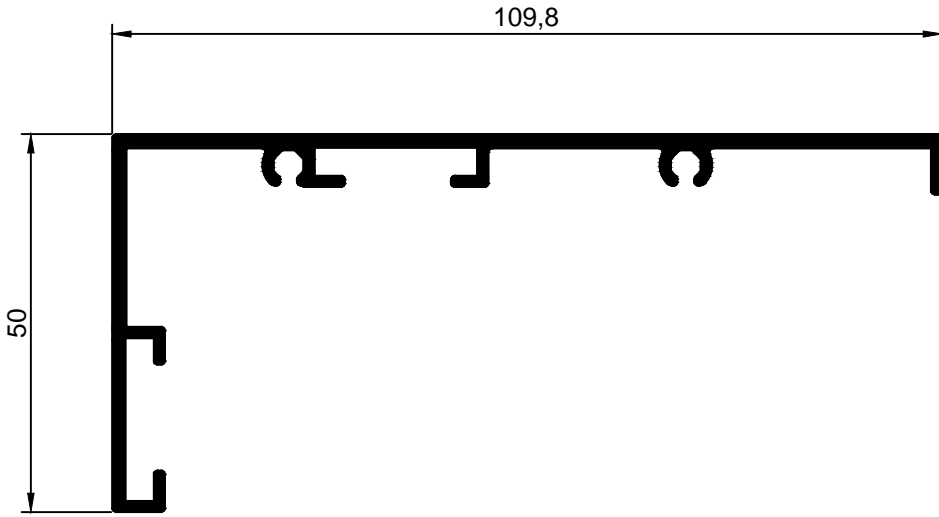

AQ.115 Remate

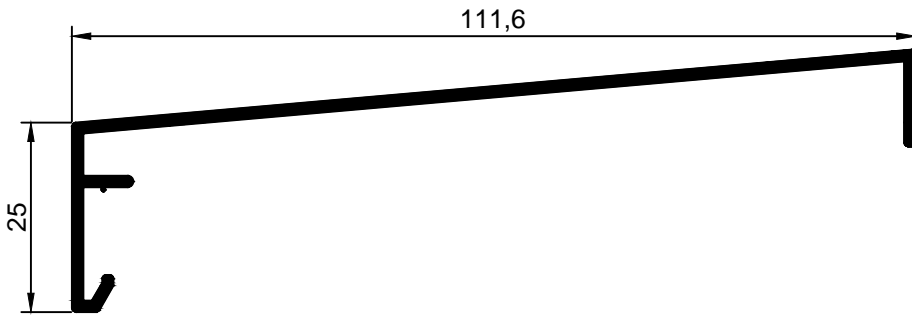

AQ.118 Remate

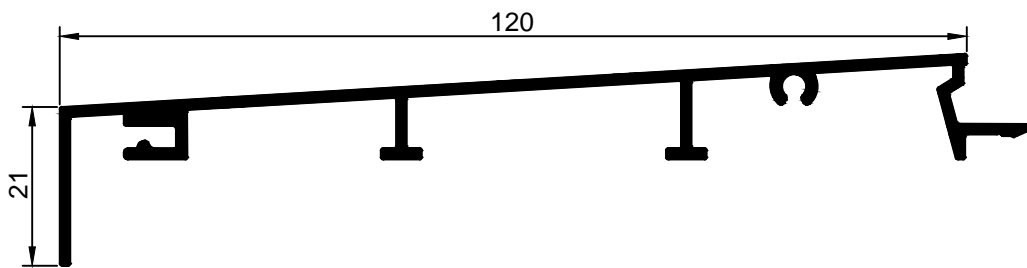

AQ.116 Esquadro P/ST.83

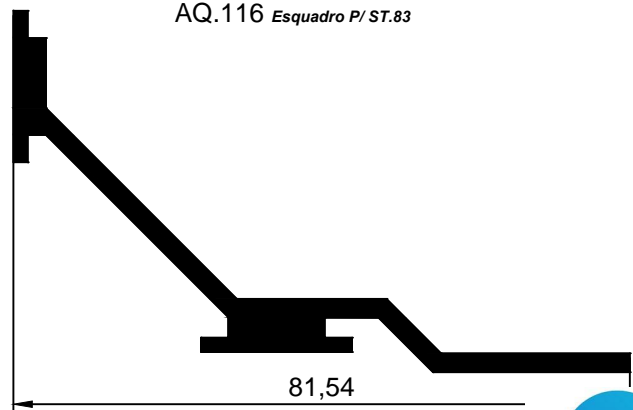

ACESSÓRIOS



ARTIGO	DESCRIÇÃO	APLICAÇÃO	
	ESQ.421 Esquadro 31,6x13,6mm	AQ01	AQ21
		AQ02	AQ22
		AQ04	AQ26
		AQ08	AQ28
		AQ12	
		AQ15	
	ESQ.406 Esquadro 36x30,5mm	AQ03	AQ32
		AQ05	AQ33
		AQ06	AQ34
		AQ11	AQ37
		AQ16	AQ38
		AQ31	
	ESQ.092P Esquadro Pequeno Misto	AQ01	AQ21
		AQ02	AQ22
		AQ04	AQ26
		AQ08	AQ28
		AQ12	
		AQ15	
	ESQ.093G Esquadro Grande Misto	AQ03	AQ32
		AQ05	AQ33
		AQ06	AQ34
		AQ11	AQ37
		AQ16	AQ38
		AQ31	
	ESQ NT45DES37X24 Esquadro Descentrado P/AQ.09 e AQ.10	AQ09	
		AQ10	
	ESQ NT45DES36X43 Esquadro Descentrado 36 x 43	AQ35	
		AQ36	
	ESQ00100 Esquadro Calço Aplicação em conjunto com o ESQ.421	AQ35	
		AQ36	

ARTIGO	DESCRIÇÃO	APLICAÇÃO	
	ESQ UNS200P Esquadro União P/ T Pequeno	AQ12	
		AQ15	
	ESQ UNS200G Esquadro União P/T Grande	AQ11	
		AQ16	
		AQ17	
		AQ18	
		AQ19	
	ESQ ALINH14 8X1 2 Esquadro de Alinhamento Inox 14.8 x 1,2	AQ21	AQ35
		AQ22	AQ36
		AQ26	
		AQ31	
		AQ32	
		AQ37	
	ESQ ALINH8 8X1 5P Esquadro de Alinhamento 8,8 x 1,5 Picado	AQ21	
		AQ22	
		AQ31	
		AQ32	
		AQ35	
		AQ37	
	ESQ ALINH15 1X1 5P Esquadro de Alinhamento 15,1 x 1,5 Picado	AQ28	
		AQ38	
	KIT 0225600K Kit Cremone 1 Folha		
	KIT 02258000K Kit Cremone 2 Folha		

ARTIGO	DESCRIÇÃO	APLICAÇÃO
	<p align="center">FECHO 49041</p> <p align="center">Fecho CE Pequeno 2ªFolha Zamak</p>	
	<p align="center">FECHO 49048</p> <p align="center">Fecho CE Medio 2ªFolha Zamak</p>	
	<p align="center">FECHO 49054</p> <p align="center">Fecho CE Grande 2ªFolha Zamak</p>	
	<p align="center">DOB 00120</p> <p align="center">Dobradiça Camara Europeia 2F</p>	<p>EXISTEM NAS CORES:</p> <p>Branco</p> <p>Preto</p> <p>Prata</p>
	<p align="center">DOB 00151</p> <p align="center">Dobradiça Camara Europeia 3F</p>	<p>EXISTEM NAS CORES:</p> <p>Branco</p> <p>Preto</p> <p>Prata</p>
	<p align="center">DOB 8020</p> <p align="center">Dobradiça Porta Pesada</p>	<p>EXISTEM NAS CORES:</p> <p>Branco</p> <p>Preto</p> <p>Prata</p> <p>Bruto</p>
	<p align="center">DOB 535</p> <p align="center">Dobradiça 535 Porta Flash</p>	<p>EXISTEM NAS CORES:</p> <p>Branco</p> <p>Preto</p> <p>Prata</p> <p>Bruto</p>

ARTIGO

DESCRIÇÃO

APLICAÇÃO



FECHA 6FAE630G62801

Fechadura Prumo 730/30 c/cilindro

FECHA 6FAE630062801

Fechadura Prumo 730/35 c/cilindro



FECHA 6FAE67L062801

Fechadura Tripla 755/30 c/cilindro

Fechadura Tripla 755/35 c/cilindro



FECHO CG0107

Fecho Bandeira c/afinação Cam.Europeia



FECHO D6030

Fecho Bandeira
perfis tradição

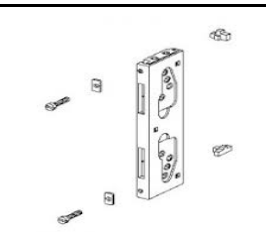
ARTIGO	DESCRIÇÃO	APLICAÇÃO
	<p>COMP 10631 - Compasso Grande</p> <p>COMP 10630 - Compasso Pequeno</p>	
	<p>COMP 12301CE</p> <p>Compasso Projectante EASY Aço Inox</p>	
	<p>COMP 1210 INOX</p> <p>Compasso Projectante</p>	
	<p>FECHO 01024</p> <p>Fecho Cremone Prima (Rapid 104)</p>	
	<p>FECHO 01007</p> <p>Fecho Cremona Supernova</p>	
	<p>KIT 02245000</p> <p>Kit Cremone Abertura Exterior</p>	
	<p>OB 04704000 - Oscilo-Batente</p> <p>OB 04711500 - Oscilo-Batente Tradição Giesse</p> <p>OB 3420G - Oscilo-Batente Ween</p> <p>OB 3520 251 - Oscilo-Batente Tradição Master</p>	

ARTIGO	DESCRIÇÃO	APLICAÇÃO
	<p>JP 6401 - Acessorio de conexão P/Jan.Proj. JP 6006 1 - Cremone p/Janela Projectante JP 4241 - Perno de Fecho P/Janela Projectante JP 4212 2 - Encontro Aste Simples P/Jan.Proj. JP 3620 3 - Kit Fecho Janela Projectante</p>	
	<p>OB 04770000K - Angulo Suplementar P/OB Giesse OB 3400G 31 - Fecho complementar OB Master</p>	
	<p>FECHO 04282000K - Fecho 2ªFolha OB Giesse FECHO 3520 34 - Fecho 2ªFolha OB Master</p>	
	<p>DOB 04718 - Dobradica 2ª Folha O/B Giesse DOB 3520 71 - Dobradiça 2ª Folha O/B Master</p>	
	<p>PUXA 02472 Puxador Muleta</p>	<p>EXISTEM NAS CORES: Branco Preto Prata</p>
	<p>FECHO 050612601 Fecho de Lingueta 7400</p>	
	<p>Ponto Fecho</p>	

ARTIGO	DESCRIÇÃO	APLICAÇÃO
	<p>TOP AQ71</p> <p>Topo P/Inversor AQ.71</p>	<p>AQ71</p>
	<p>TOP AQ72</p> <p>Topo P/Inversor AQ.72</p>	<p>AQ72</p>
	<p>TOP 353</p> <p>Topo Pingadeira</p>	<p>AQ96</p>
	<p>VD 6004</p> <p>Vedante Central EPDM AQ</p>	
	<p>VD 6040</p> <p>Vedante Batente EPDM</p>	
	<p>VD 6030</p> <p>Vedante Batente EPDM Serie AQ</p>	

ARTIGO

DESCRIÇÃO

APLICAÇÃO

Diagramas

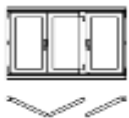

2 + 1

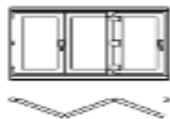

3

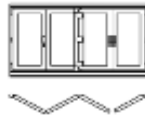

3 + 1

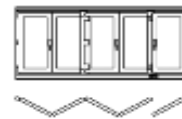

4 + 1

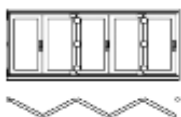

5

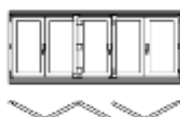

3 + 2

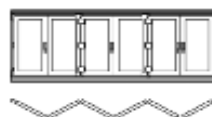

6

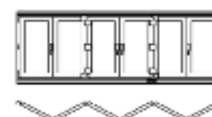

3 + 3

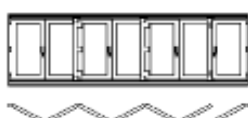

6 + 1

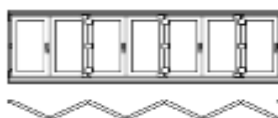

7

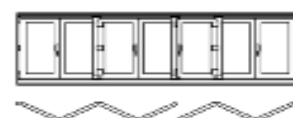

4 + 3

Importante:

Largura Mínima Por Folha: 350mm
Largura Máxima Por Folha: 900mm
Altura Mínima Por Folha: 850mm
Altura Máxima Por Folha: 2400mm
Peso Máximo Por Folha: 80 Kg

ARTIGO

DESCRIÇÃO

APLICAÇÃO

Conjunto Oscilo-Paralela

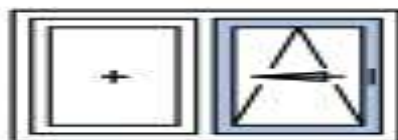
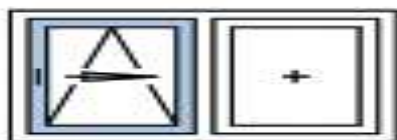

Importante:

Altura Mínima: 850mm

Altura Máxima: 2400mm

Peso Máximo: 150 Kg

FORMENORES TÉCNICOS



SÉRIE AQ

FIXO

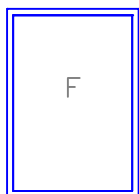

corte vertical
escala: 1/2

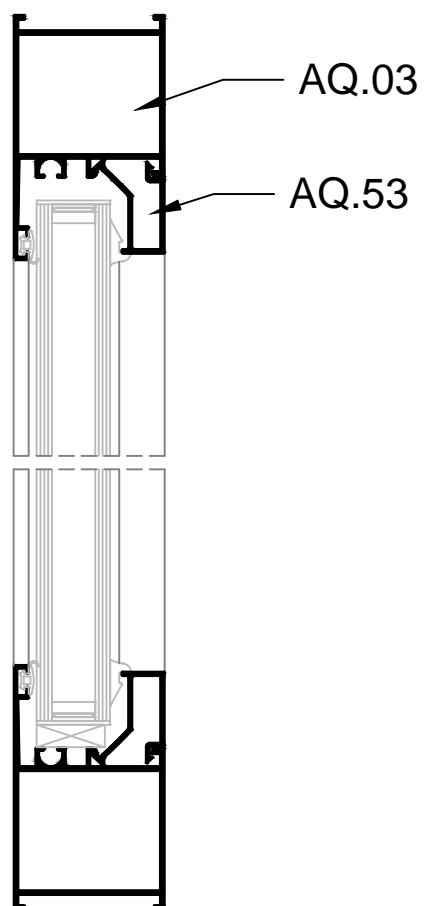

corte horizontal
escala: 1/2



SÉRIE AQ
BASCULANTE

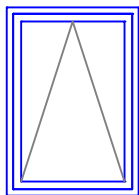

corte vertical
escala: 1/2

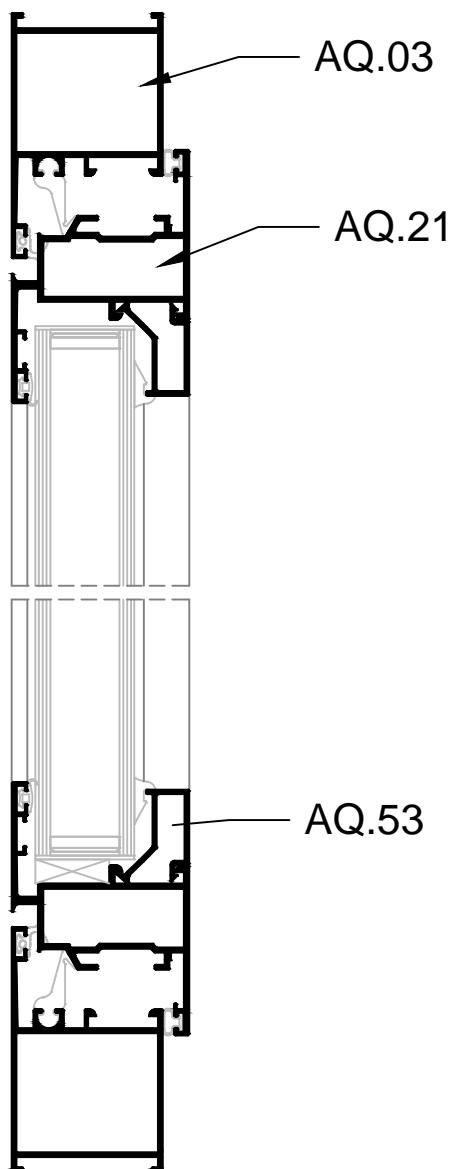

corte horizontal
escala: 1/2

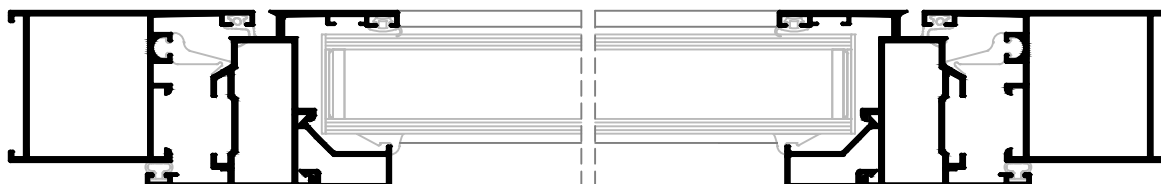

SÉRIE AQ
JANELA ABRIR 1F

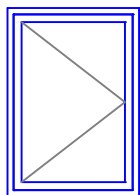

corte vertical
escala: 1/2

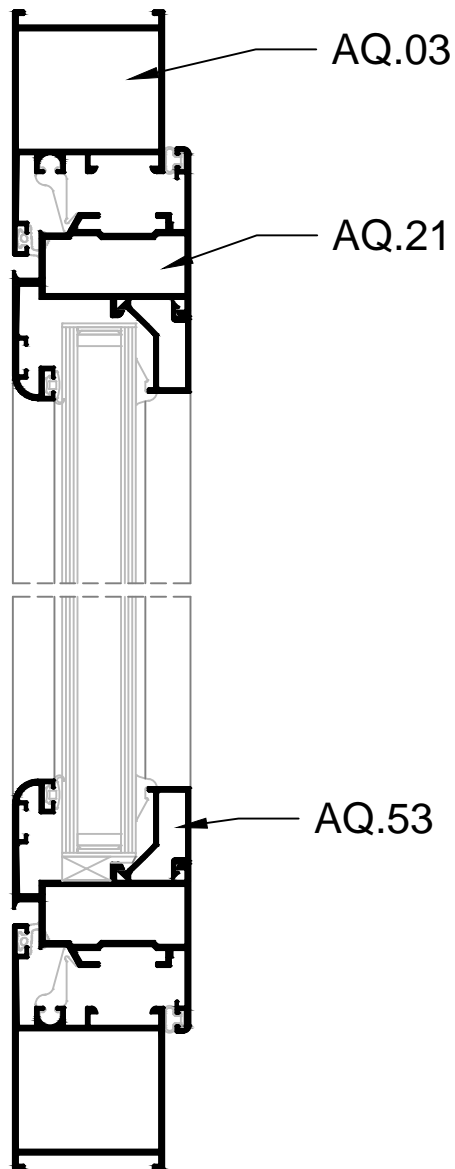

corte horizontal
escala: 1/2

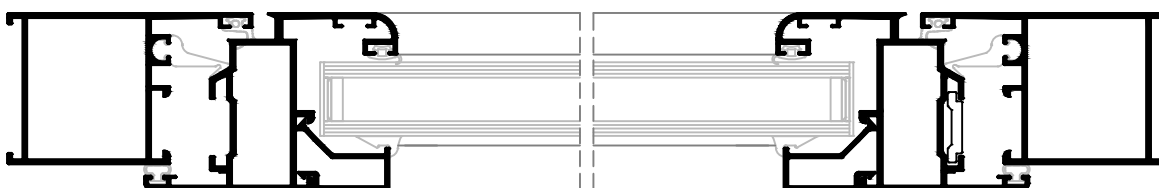

SÉRIE AQ

JANELA ABRIR 1F C/ OB + FIXO

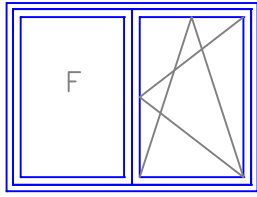

corte vertical
escala: 1/2

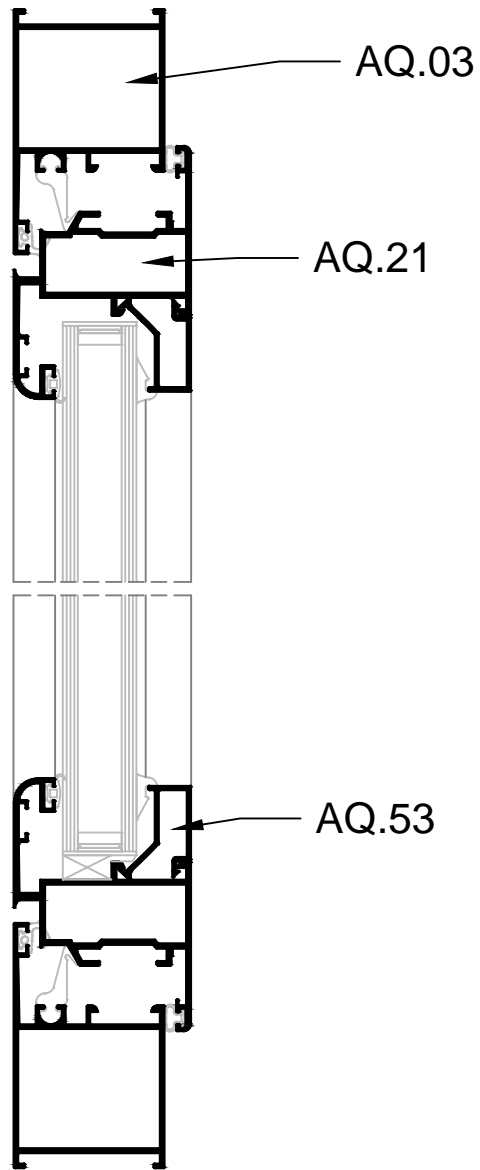

corte horizontal
escala: 1/2

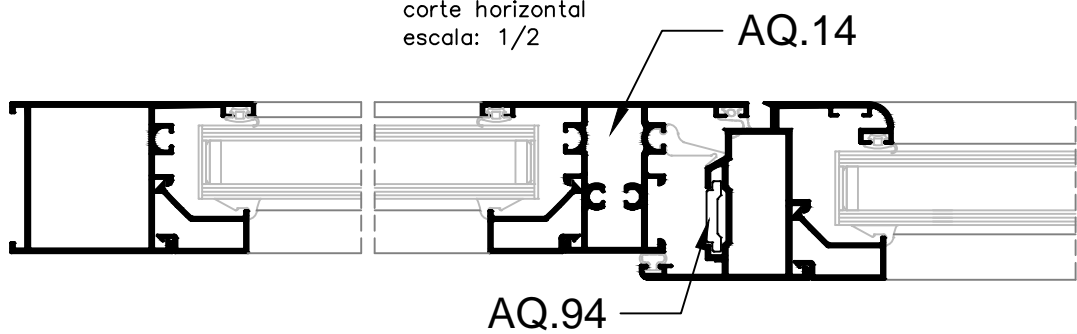

SÉRIE AQ

JANELA ABRIR 2F

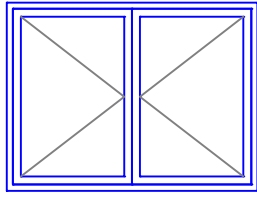

corte vertical
escala: 1/2

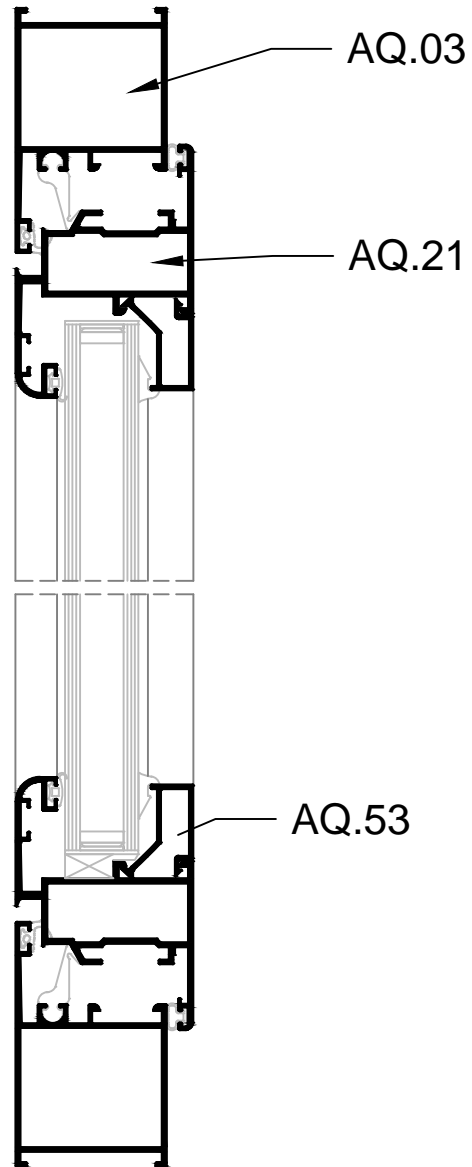

corte horizontal
escala: 1/2

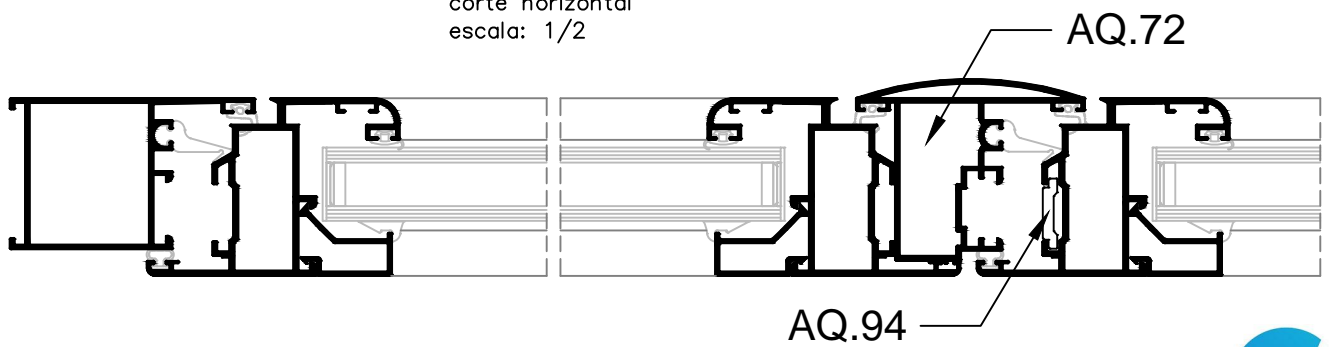

SÉRIE AQ

JANELA PROJECTANTE

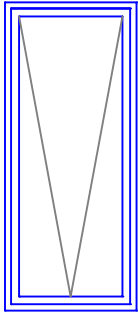

corte vertical
escala: 1/2

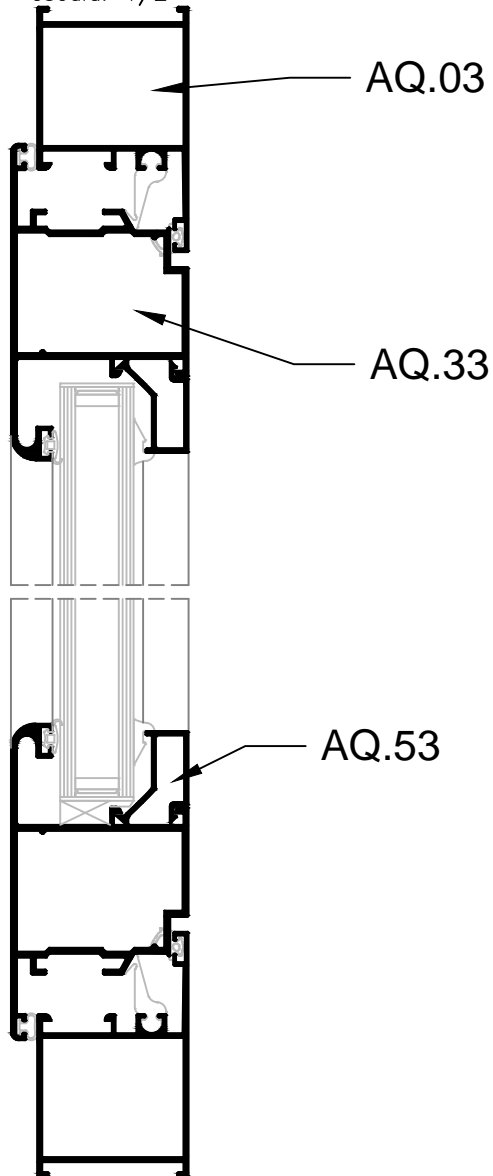

corte horizontal
escala: 1/2

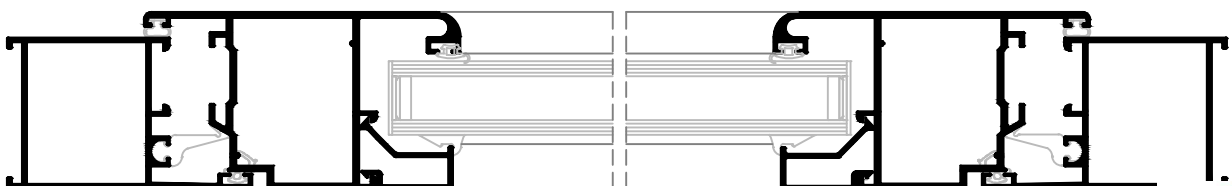

SÉRIE AQ
PORTA ABRIR 1F

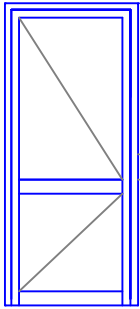

corte vertical
escala: 1/2

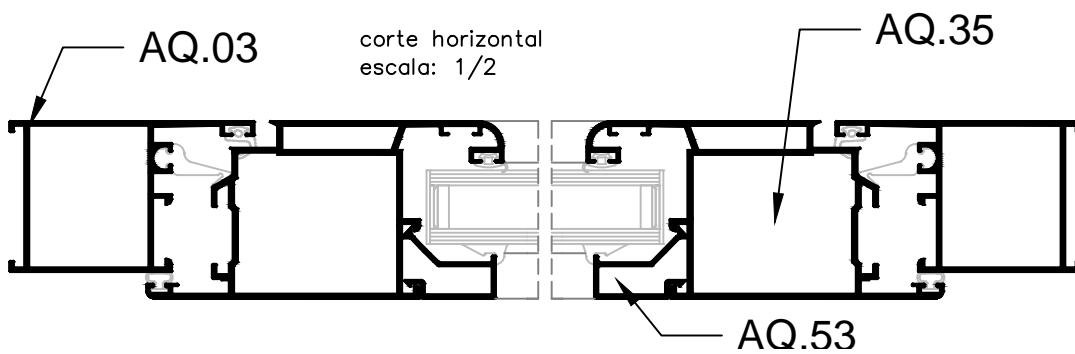
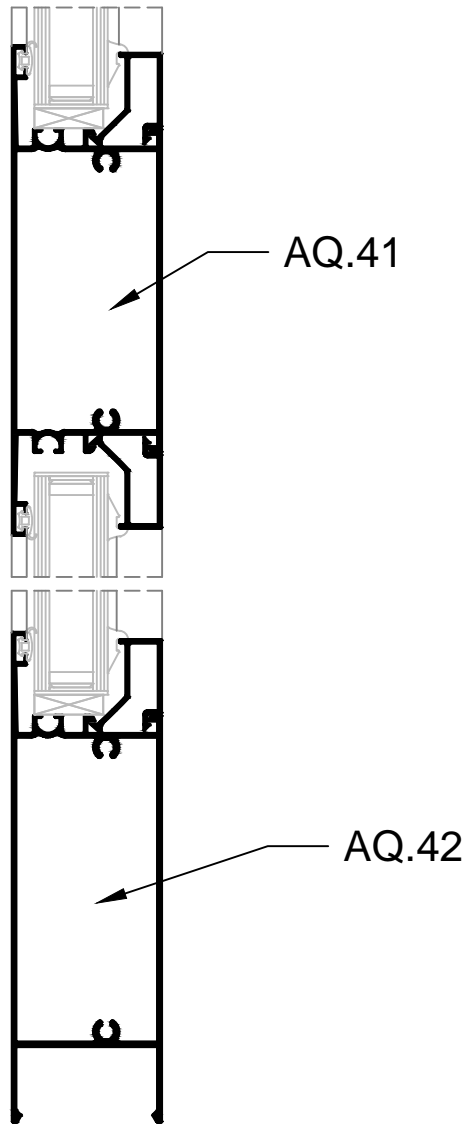

SÉRIE AQ
PORTA ABRIR 2F

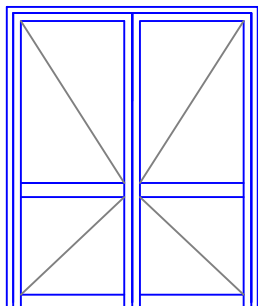

corte vertical
escala: 1/2

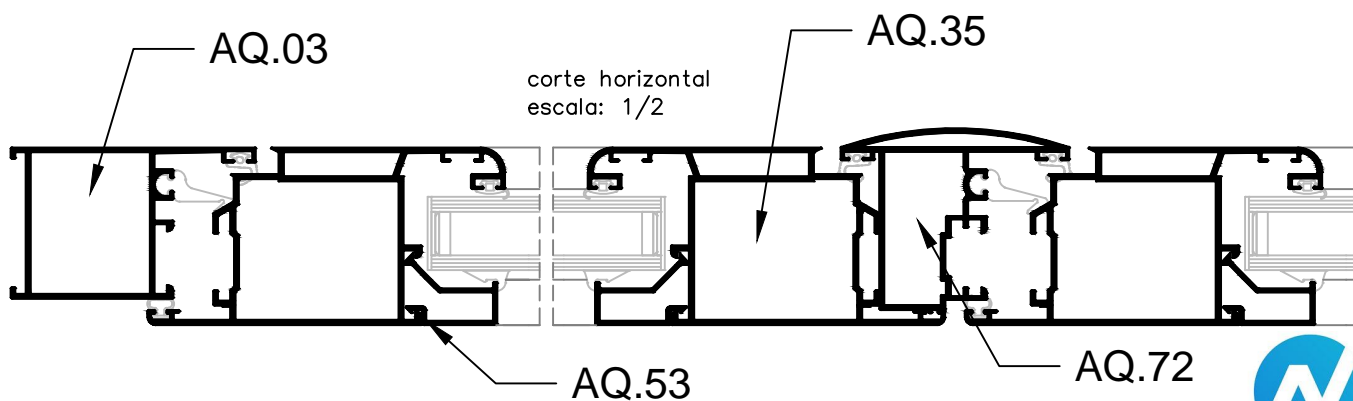
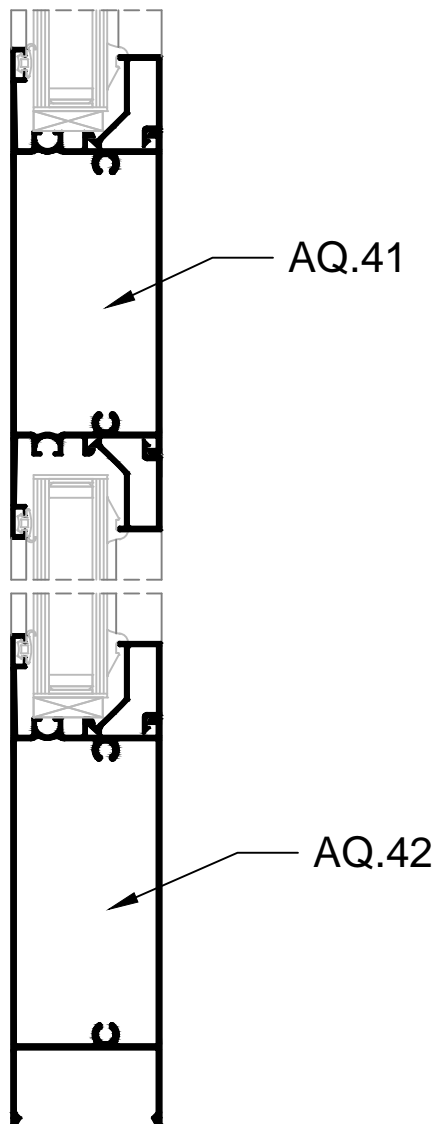

corte horizontal
escala: 1/2